

EM-750 Midi Magnet Lock WaterProof



Waterproof Test:
Reference to IEC 60529 Edition 2.1: 2001-02-IPX7

Feature

- High reliability
- Dual voltage 12 or 24 VDC (selectable)
- MOV provides spike and surge protection
- Anti-residual magnetism function
- Holding force up to 800 lbs

Statement

The EM-750 Electromagnetic Lock design with no mechanical parts but magnetic force to secure and release the doors, suitable for use in areas which required access controlled or egress such as exit door.

The Electromagnetic Locks are totally sealed in an epoxy filled stainless steel case for water-resistant and vandal-resistant purpose. A threaded conduit fitting ensures weather resistant protection of the wiring therefore it is ideal for indoor and outdoor applications, even in severe weather.

Specifications

- Operating voltage: 12 VDC
- Current Draw: 340mA/12VDC (at temperature 20°C)
- Magnetic bond sensor monitor output (EM-750R)
:SPDT rated 0.5A/20VDC.
- Operating Temperature: -10~55°C (14~131°F)
- Humidity: 0~95% non-condensing.
- Holding Force: Up to 800 lbs (363 K)
- Dimensions:
 - Magnet:(L) 230, (W) 46, (D) 30 mm
 - Armature Plate:(L) 185, (W) 45, (D) 14 mm
- Special Finishes for magnet and armature plate: Zinc plated
- Epoxy Potting Compound: E87252 (S), UL94V-0
- Net Weight: 3.0 Kg

Regular Installation

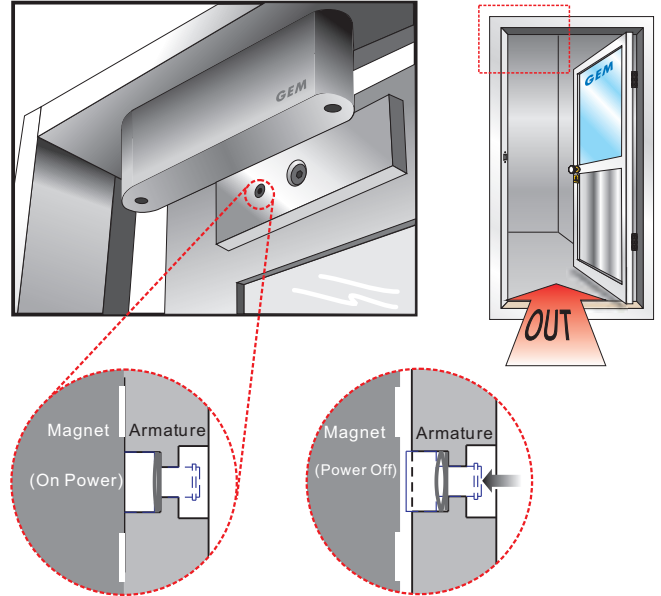

Anti-residual statement

Our electromagnet locks feature Anti-Residual Magnetism (ARM) which ensures the door can be opened without any resistance from left over magnetism imparted to the armature plate



This series of Waterproof Magnetic Lock is made with epoxy potting compound and is protected by this compound. Also, GEM Waterproof Series Magnetic Locks have been proved to have withstood a water resistance as established in accordance with the test procedures of IPX7, IPX8 through a trusted third party. Therefore users need not worry that the lock will be rusted or sparked, if the lock is using in outdoor applications and installing in confined space where any inflammable gas.

Warranty

The product is warranted against defects in material and workmanship while used in normal service for a period of 5 year from the date of sale to the original customer. The GEM policy is one of continual development and improvement; therefore GEM reserves the right to change specifications without notice.

Optional Brackets

Brackets installation are according to door swing direction and door frame type , e.g. narrow frame door , frameless glass door , inswing door , etc.

With L-bracket for narrow door frames

When "A" < 48 mm , must installed with "L" brackets.

L-750

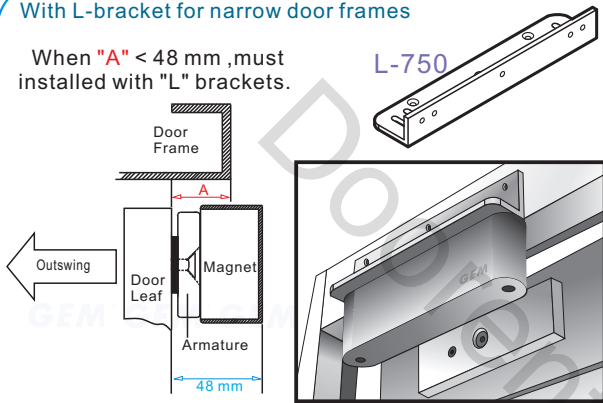

With LZ-bracket for inswing doors

LZ-750

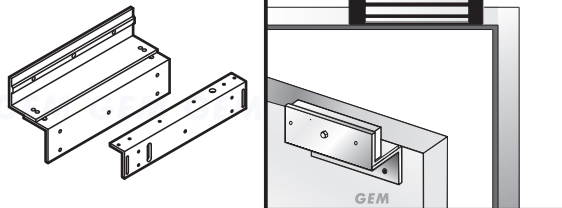

With U-bracket for frameless glass doors

UBK-013 For 10~12mm glass thickness

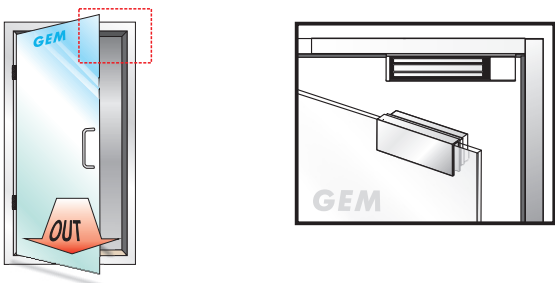

Electromagnetic Lock Installation Instruction (Indoor Series)

Optional Bracket

Brackets installation are according to door swing direction and door frame type , e. g. narrow frame door , frameless glass door , inswing door , etc.

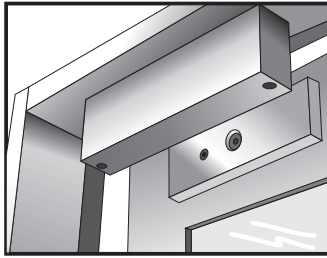

Regular Installation
(outswing door)

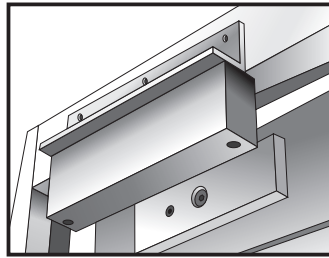

With L-bracket for narrow
frames (optional)

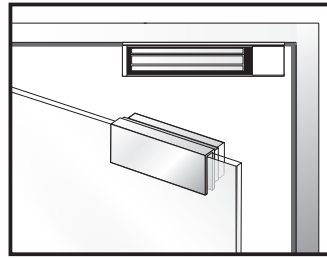

With U-bracket for frameless
glass door (optional)

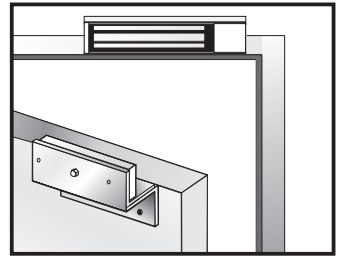

With LZ-bracket for inswing
door (optional)

Regular Installation

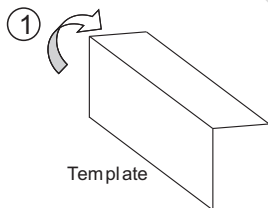

1 Fold the mounting template as a 90° angle.

Template

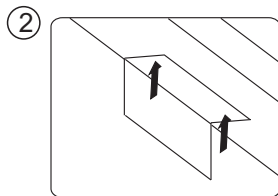

2 Place the template to the proper position of the door and frame. Mark the hole position of template to the door frame.

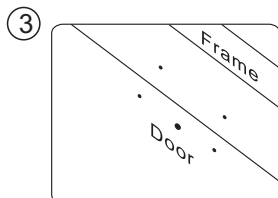

3 Drill the holes according to the mark.

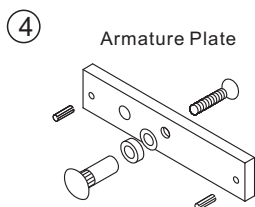

4 **Armature Plate**
Please install the armature plate as the diagram. (Different dimension of the drilling holes are according to the door type as below instruction)

Hollow Metal Door

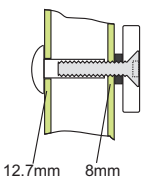

12.7mm 8mm

Reinforced Door

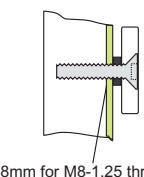

6.8mm for M8-1.25 thread

Solid Door

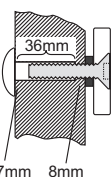

12.7mm 8mm
36mm

Drill a Ø8mm hole through door, from sexnut bolt side, enlarge to Ø12.7mm.

Drill a Ø6.8mm hole and tap for M8x12.5 thread.

Drill a Ø8mm hole through door from sexnut bolt side enlarge to Ø 12.7mm, 36mm in depth.

Recommendation:

- Micro EM-locks (300 LBS) maximum thickness of door is 44 mm.
- Mini EM-locks (600 LBS) maximum thickness of door is 50 mm.
- Midi EM-locks (800 LBS) maximum thickness of door is 48 mm.
- Maxi EM-locks (1200 LBS) maximum thickness of door is 46 mm.

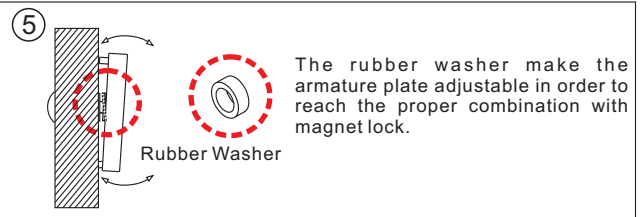

5 The rubber washer make the armature plate adjustable in order to reach the proper combination with magnet lock.

Rubber Washer

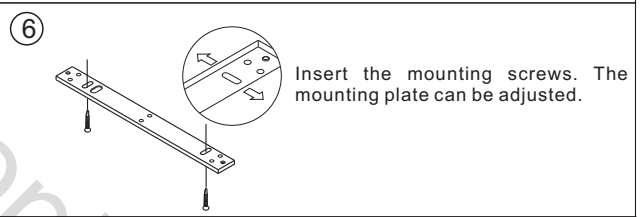

6 Insert the mounting screws. The mounting plate can be adjusted.

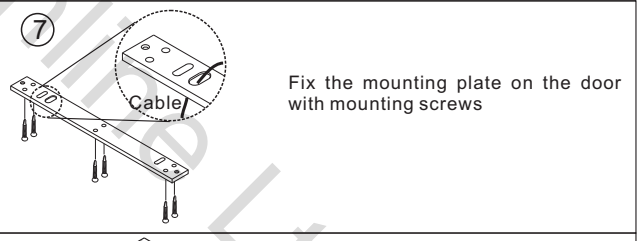

7 Fix the mounting plate on the door with mounting screws

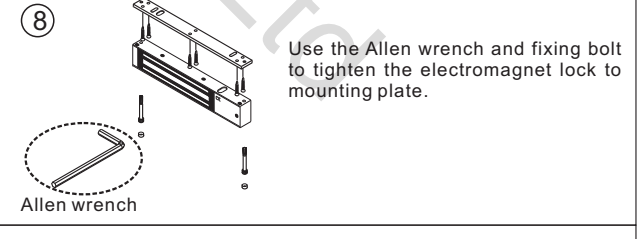

8 Use the Allen wrench and fixing bolt to tighten the electromagnetic lock to mounting plate.

Allen wrench

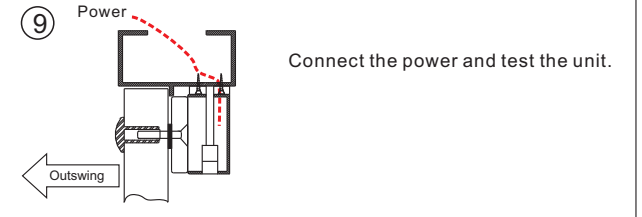

9 Connect the power and test the unit.

Outswing

With LZ bracket for Inswing doors

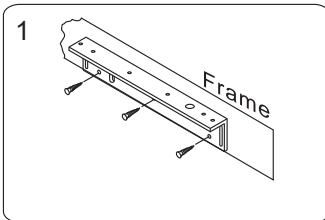

1 Find a mounting location on the door frame for the L bracket. Make sure that the door is still closeable.

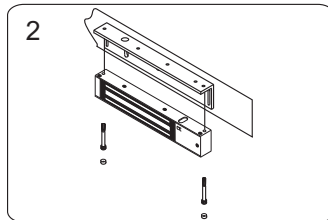

2 Use the fixing bolt to tighten the electromagnet lock on L bracket.

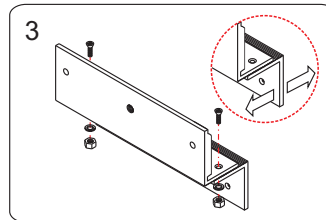

3 Assemble the Z bracket, and make sure that the Z bracket is adjustable.

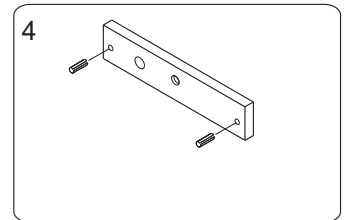

4 Insert the guide pins into the armature plate.

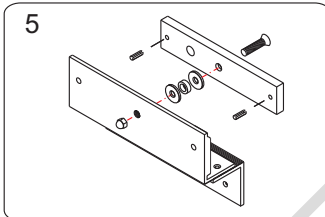

5 Assemble the armature plate (Rubber washer must be added)

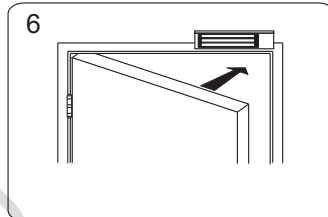

6 Close the door and connect the power.

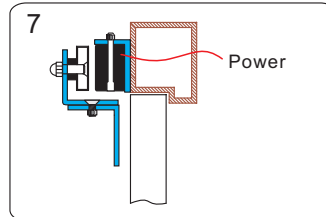

7 Adjust the position between Z bracket and the door frame. Then fix the Z bracket.

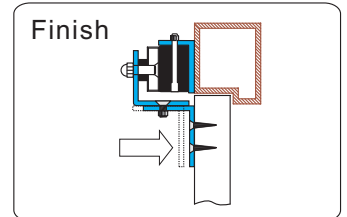

Finish Connect the power and test the unit.

Connecting Diagram

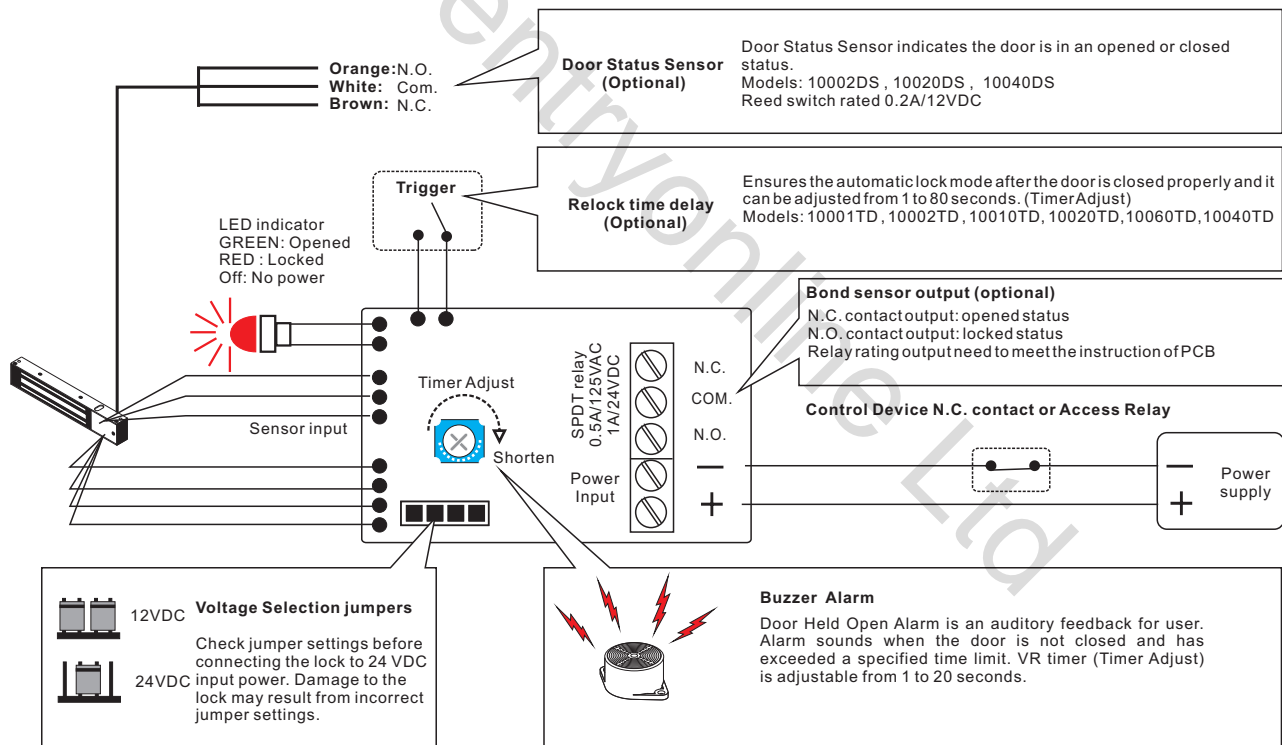

Trouble Shooting

Problem	Possible Cause	Solution
Door does not lock	No power	Make sure the wires are connected properly Check that the power supply is connected and working properly Make sure the lock switch is wired correctly
Low holding force	Poor contact between electromagnet and armature plate	Make sure if the armature plate is deformed? Make sure if the rubber washer was used between magnet lock and armature plate Make sure the contact surfaces of the electromagnet and armature plate are clean and free from dust
	Low voltage or incorrect voltage setting	Ensure the electromagnet lock is set for the correct voltage. Check for proper voltage at the electromagnetic locks input. If low, determine if the correct wire gauge is being used to prevent excessive voltage drop.
Sensor output is not functioning	A secondary diode was installed across the electromagnet lock	Remove any diode installed across the magnet for "spike" suppression. (The magnet is fitted with a metal oxide varistor to prevent back EMF)
	Misalignment between the reed switch and electromagnet lock	Make sure the armature plate and electromagnet lock are aligned correctly