

## SPECIFICATION

Dimensions	75 x 45 mm.
Input Voltage	9 to 28V DC. 7 to 20V AC.
Input Current	3mA (Relay off). 45mA (Relay on).
Output	Changeover Relay contacts. Contact ratings. 120VAC / 60VDC @ 2A
Trigger Inputs	Clean Contact (N/O or N/C) selectable  Voltage Input 9 to 28V DC or 7 to 20V AC Operate when voltage applied / removed selectable
Timer Range	Two selectable ranges 0.25 to 15 seconds adjustable using potentiometer 2 seconds to 3.5 minutes adjustable using potentiometer
Operation	Option 1. Operate when trigger applied.  Option 2. Delay operation until after the preset time and only if the trigger signal remains.

## TDR5

### TIMER DOOR RELAY MODULE

#### INTRODUCTION

The TDR5 is a simple to use and highly versatile timer relay. The relay coil will operate over a wide range of voltages (9 – 28V DC, 7 – 20V AC) and has LED indication to show the relay operation.

#### OPERATION

The relay can be configured to operate in 2 ways: -

**Option 1.** The relay will operate for the preset time as soon as a trigger signal is present. It will not operate again until the trigger signal is removed and re applied. This option is selected by leaving LINK 1 UNCUT.

**Option 2.** The relay will not operate until after the preset time and only if the trigger signal remains during the timing period, once operated the relay will remain active until the trigger signal is no longer present. This option is selected by CUTTING LINK 1.

**Timing.** Two timing ranges are available 0.25s to 15s selected by leaving LINK 2 UNCUT and 2s to 3.5mins selected by CUTTING LINK 2. Adjustment within these ranges is via a potentiometer P1.

**Inputs.** Two types of input are catered for. A clean contact input (e.g. door contacts or push buttons) and a voltage input (9 to 28V DC or 7 to 20V AC). These inputs can be selected to trigger normally open or normally closed. To trigger the timer if the input is shorted or a voltage is applied (normally open) leave LINK 3 UNCUT. To have timer trigger if the input is opened or the voltage is removed (normally closed) then CUT LINK 3.

**With normally closed operation only one of the inputs can be used.**

#### CONNECTION

Terminal (CN1) marked PWR is for connection to either an AC or DC power supply in the range 9-28V DC or 7-20V AC. The voltage input is not polarity conscious.

Terminal (CN2) marked NC, C, NO are voltage free changeover contacts.

Terminal (CN3) marked PB is the clean contact input for connection to push buttons etc.

Terminal (CN4) marked VT is the voltage input and will trigger on either AC or DC in the following range 9-28V DC or 7-20V AC. The voltage input is not polarity conscious.

## WIRING EXAMPLES

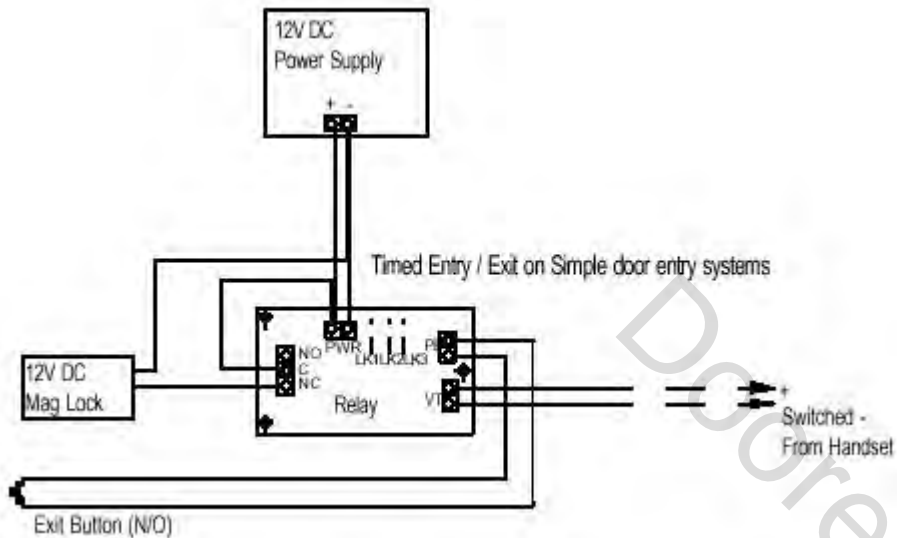

This example shows how to wire to a simple door entry system to achieve timed entry / exit operating a magnetic lock. Pressing the exit button or operating the lock button on the handset will operate the relay for the preset time, removing power from the lock. This configuration has links 1,2 and 3 uncut. Cut link 2 if relay operation is to be greater than 15s.

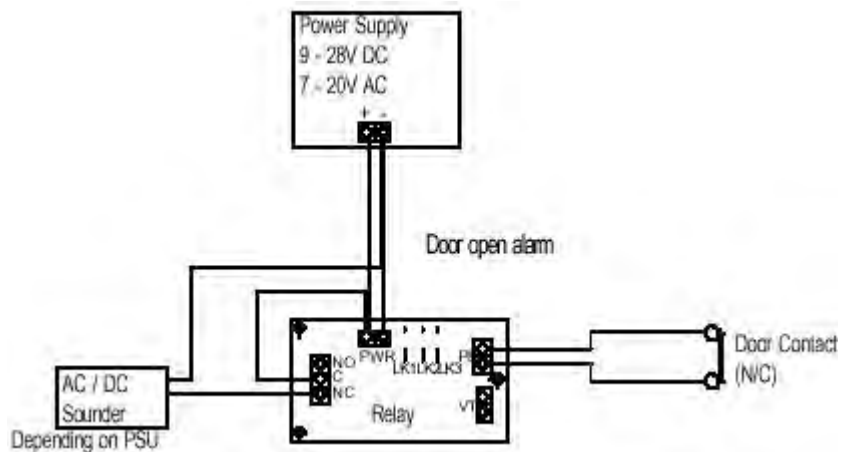

This example shows how to wire a simple door monitor alarm. When the contacts are opened the timer will start. If the door remains open after the preset time period the relay will activate, operating the sounder. The sounder will sound until the door is closed. If the door is closed before the timer period ends the relay will not operate. This configuration has links 1 and 3 cut. Cut link 2 if delay is to be greater than 15s. **When set for normally closed operation only one input may be used.**

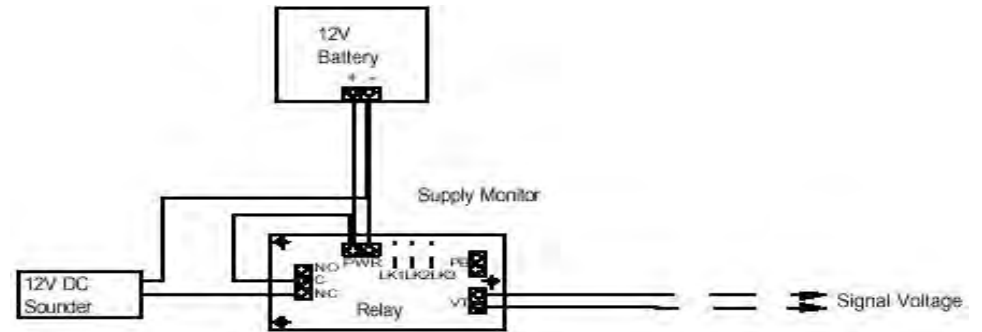

This example shows how to wire a simple voltage monitor alarm. While the voltage is present (AC or DC in the range 9-28V DC or 7-20V AC) the relay will not operate. When the voltage is removed the timer will start. If the voltage does not return before the preset time period ends the relay will activate operating the sounder. The sounder will sound until the voltage is restored. This configuration has links 1 and 3 cut. Cut link 2 if delay is to be greater than 15s. **When set for normally closed operation only one input may be used.**

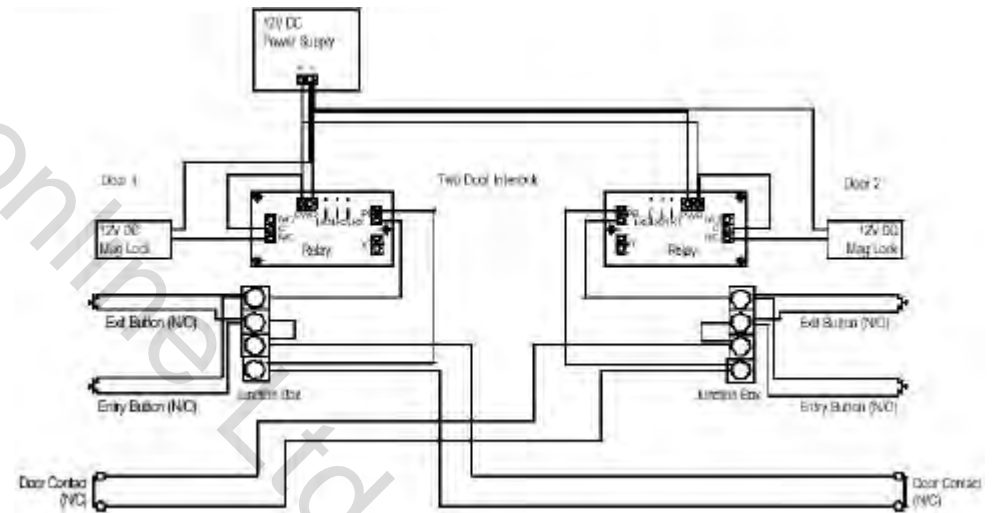

This example shows how to wire a simple two-door interlock using magnetic locks and entry / exit buttons. Pressing the entry button will operate the lock allowing the door to be opened. The entry and exit buttons are wired through the door contact of the opposite door so will not operate when the door is open. The lock time should be set to the minimum required; this allows the door to lock when closed. This configuration has links 1,2 and 3 uncut.