

GD-870 Door Holder

GD-870 (Wall Surface Mount)

Input Voltage: 24Vdc/ac (12V available by special order)

Current Draw: 60mA@24Vdc

(Further notice for 12Vdc input voltage on special order requirement)

Release Button: Manually controlled for instant closing for safety reasons.

Holding Force: up to 80 lbs.

Unique Anti-Residual design

White Color Finishing to match your room decor.

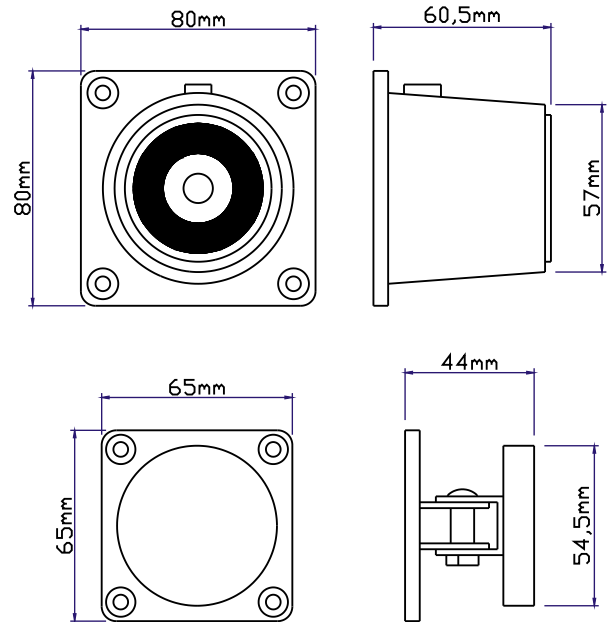

Specifications:

The GD-870 series door holder is a fail-safe unit energized by a power supply installed on large-scale building, between fire escape doors. It releases the armature plate allowing the door closer to close the door when the fire prevention system detects a fire alarm or emergency. The electromagnetic door holder are constructed with a PUSH OFF button on magnet for instant release, the door can be opened or closed manually at any time.

Warranty:

GEM access control related accessories are warranted against defects in material and workmanship while used in normal service for a period of 1 year from the date of sale to the original customer.

Disclaimer:

The information and specifications printed in this manual are current at the time of publication. The GEM policy is one of continual development and improvement; therefore GEM reserves the right to change specifications without notice.

Application :

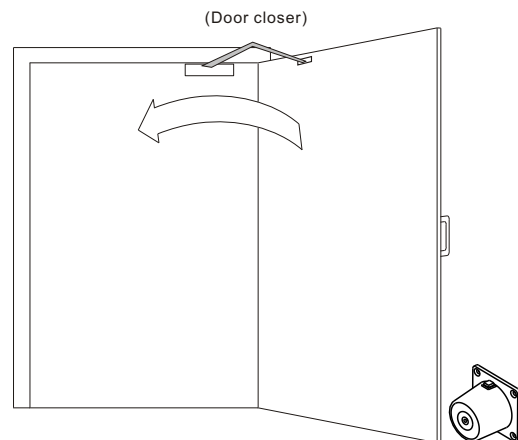

GD-870

Wall Surface Mount