

# GS-200/GS-300 Serial Mini Shear Lock Installation Instruction

## Specifications

Holding Force	Up to 1500 lbs (680 Kg) in shear.
Power Input	12/24 VDC selectable via jumpers +10% over voltage is acceptable, under voltage will reduce holding force.
Current Draw	0.35 A@12 VDC; 0.19 A@24 VDC The unit does not require initial voltage increase to operate.
Finish	Magnet and Armature: Zinc plated,
Monitoring Output (GS-200M, GS-300M)	Magnet bond sensor output, SPDT rating 3 AMP@30 VDC
Door Gap	2mm (The Gap between the Lock and Armature plate)
Operating Temper.	-30C to +50C

### Caution:

Make sure that the "+" and "-" wire are connected correctly. Failure to observe polarity will result in a short circuit and is not covered by products warrant.

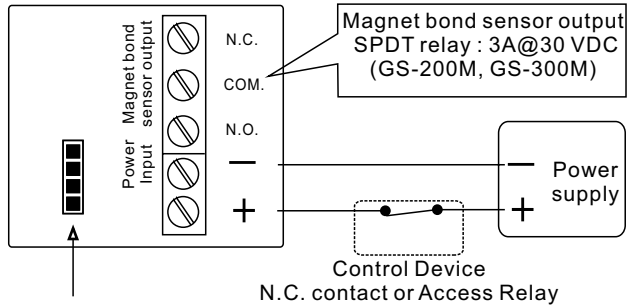

 12Vdc Voltage Selection jumpers Check jumper settings before connecting the lock to 24 VDC input power. Damage to the lock may result from incorrect jumper settings.

 24Vdc

## Dimensions

### GS-200 Flush Mount

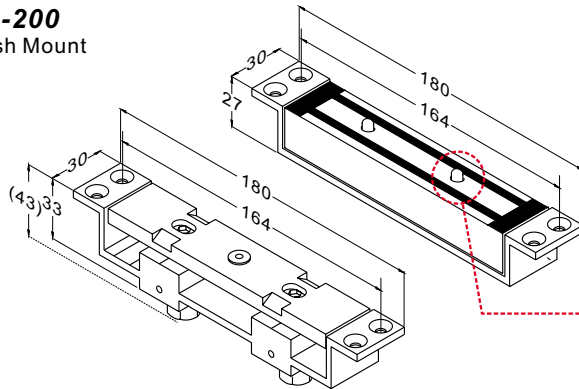

#### Locking Bolt

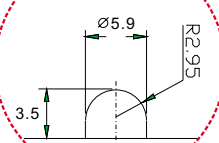

#### Magnet Assembly

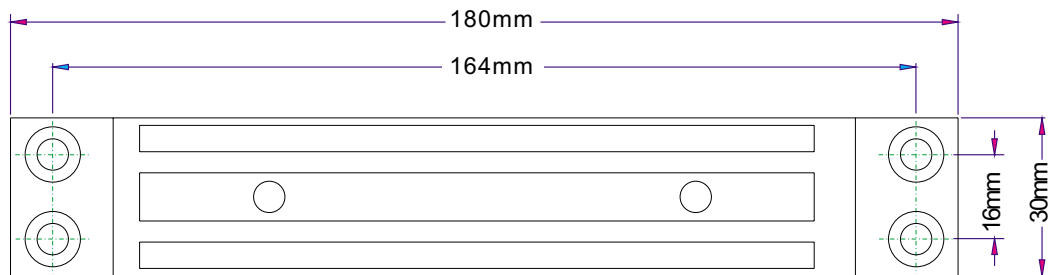

#### Armature Assembly

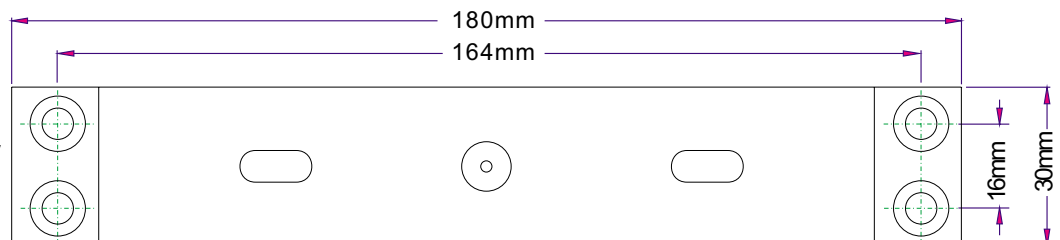

## Important Notes

Install the magnet assembly into the door frame before installation the armature assembly into the door leaf. The magnet assembly requires space to run wires, as well as space for the recessed portion of the unit. However, make sure that the position selected for the magnet assembly leaves enough room on the door to install the armature assembly.

Unbalanced air conditioning (stack pressure) can hinder door alignment and must be corrected to help insure positive locking. It is important to note that the Shear Locks need a regulated 12V DC (or 24VDC) at the lock, and use the highest quality door closer only. Positive centering door closers are required for all double acting door applicators to help attain consistent dead center alignment. Also the door latching problems must be corrected prior to installation.

## Flush Installation

1. Make sure the gap between the door top rail and frame header is 2mm. Make adjustments to the door as required.
2. Adjust single acting door and door closer to insure the door settles immediately and is fully closed. (Adjust double acting door and POSITIVE CENTERING DOOR CLOSER to insure the door settles immediately and is fully closed and rest in the dead center of the frame.)
3. Locate the vertical centerline of the magnet and armature as possible to the leading door edge.
4. Determine the horizontal centerline of the door top rail thickness. The Armature centerline will be the same. Mark the door per template.
5. Before determining the frame header centerline single acting door must be fully closed. Double acting doors must be fully closed and rest in the dead center of the frame. Mark the frame header per the template. Prepare the door and frame per the template.
6. Install the Shear lock and armature assembly towards the leading edge of the door.
7. For proper operation the armature must be adjusted upward as close as possible and parallel to the Shear Lock without interfering with opening and closing of the door.
8. Proper operation cannot be expected with more than 2 mm gap between the armature and the magnet. Use the key wrench provided to adjust the armature vertical adjustment screws.
9. With the door closed turn the lock power on, check the lateral alignment. The armature locking bolt should be centered to magnet keep hole.
10. If the shear stops are too close or binding, double check the templating and door alignment, and make corrections as required.
11. Repeat steps 6~10 as necessary following shear lock replacement. Cycle the door and Shear Lock several times after the completion of the installation.

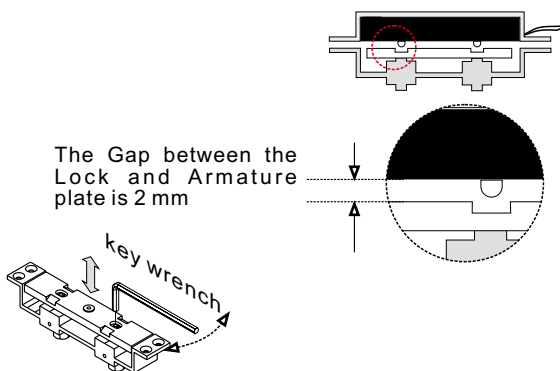

Proper operation cannot be expected with more than 2 mm gap between the armature and the magnet. Use the key wrench provided to adjust the armature vertical adjustment screws.

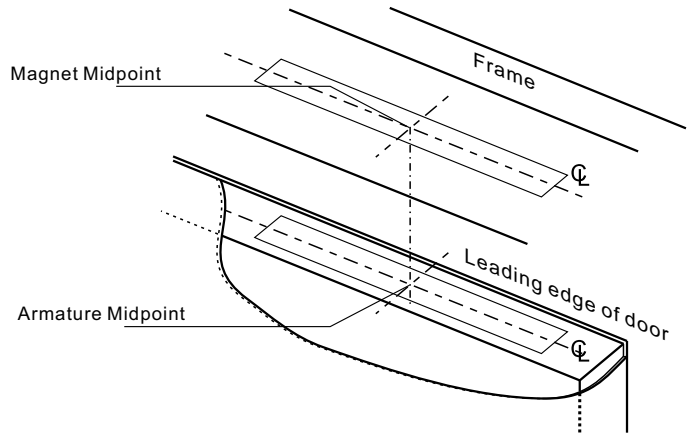

The most important elements for the proper installation of the Shear Lock magnet assembly are that the midpoint of the armature, and the midpoint of the magnet must line up exactly. All centerlines of the armature must line up with the respective centerlines of the magnet.

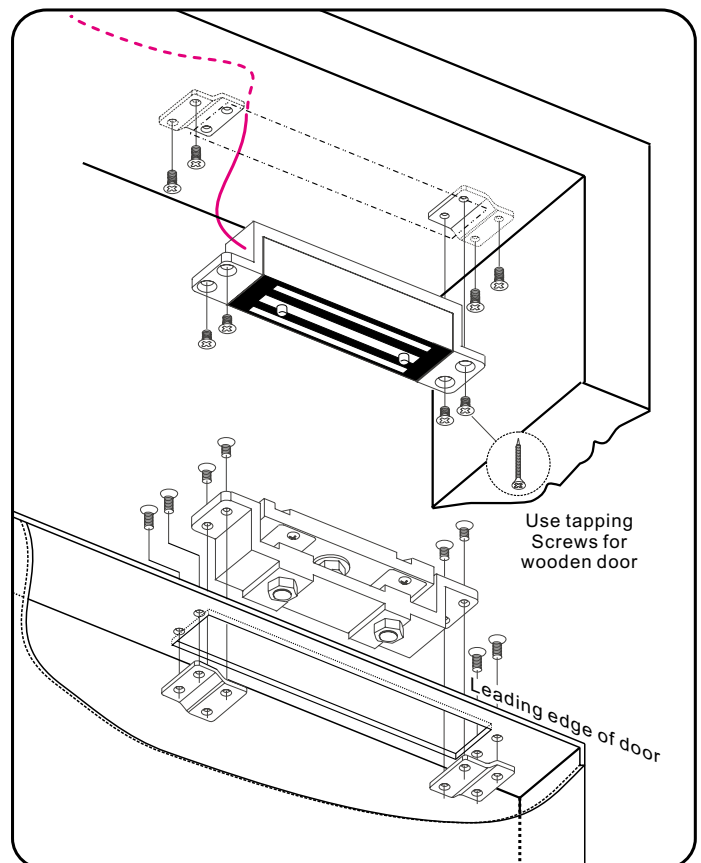
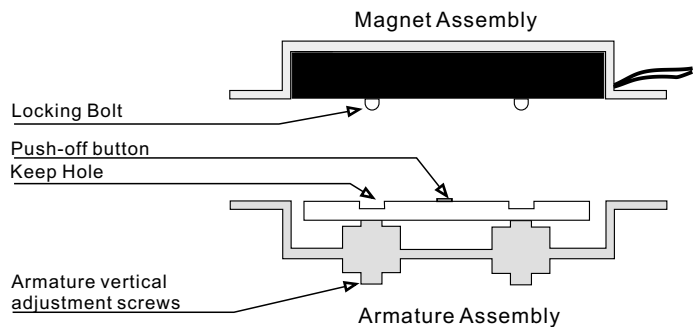

## Optional Bracket

The unit may also be fitted semi-flush with the use of the SMB-200 Bracket. The magnet should be fitted to the door transom and the housing holding the armature on to the door. It is vital that a minimum gap of 2mm exists between the magnet and the armature, to allow correct operation.

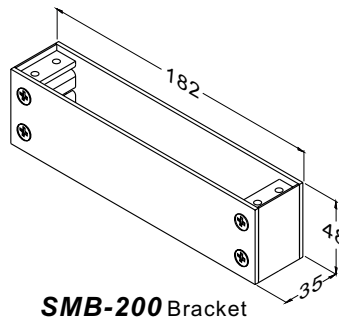

**SMB-200** Bracket

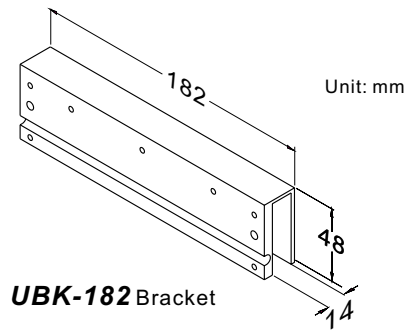

**UBK-182** Bracket

Unit: mm

## Semi-Flush Installation

The **GS-200** may also be fitted semi-flush with the use of the SMB-200 Bracket. The magnet should be fitted to the door transom and the housing holding the armature on to the door. It is vital that a minimum gap of 2mm exists between the magnet and the armature, to allow correct operation.

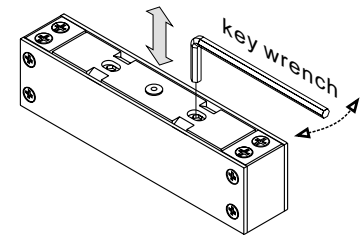
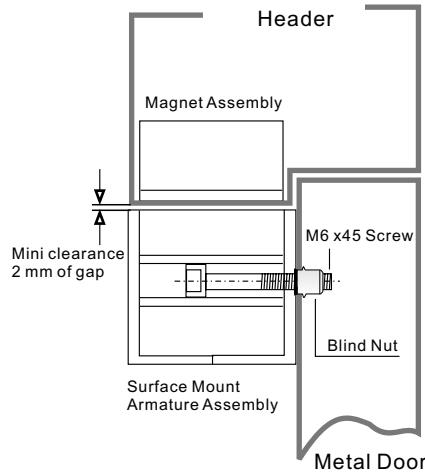

Using supplied key wrench to adjust armature plate to approx. 2 mm of gap between magnet surface.

## Surface Installation

The **GS-200** may also be fitted surface mounted using 2pcs of the SMB-200 Bracket. The magnet should be fitted above the door and the housing holding the armature on to the door. It is vital that a minimum gap of 2mm exists between the magnet and the armature, to allow correct operation.

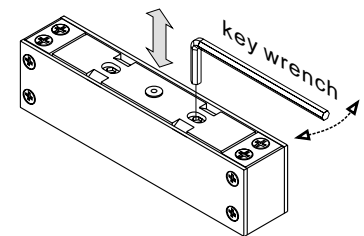
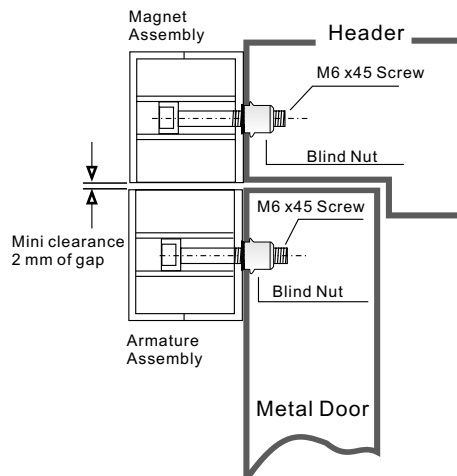

Using supplied key wrench to adjust armature plate to approx. 2 mm of gap between magnet surface.

## Installation on Frameless Glass Door

The **GS-200** may also be fitted to a full glass door and glass frame application, using 2pcs of the **SMB-200** Bracket and 2pcs of the **UBK-182** mounting brackets. (The thickness of glass are 14 mm maximum.) The housing holding the magnet should be clapped above the door and the housing holding the armature clapped on to the door.

It is vital that a minimum gap of 2mm exists between the magnet and the armature, to allow correct operation.

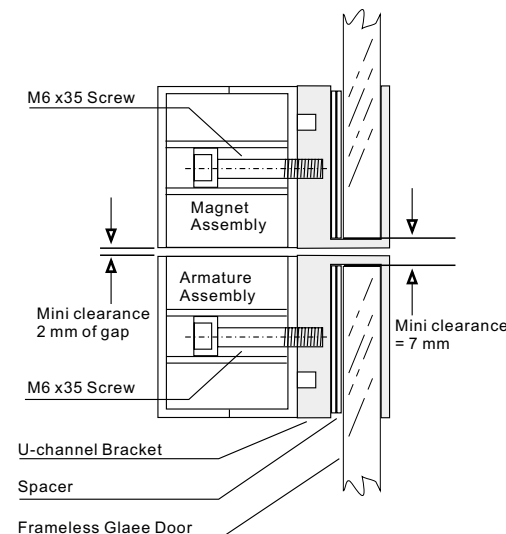

Using supplied key wrench to adjust armature plate to approx. 2 mm of gap between magnet surface.

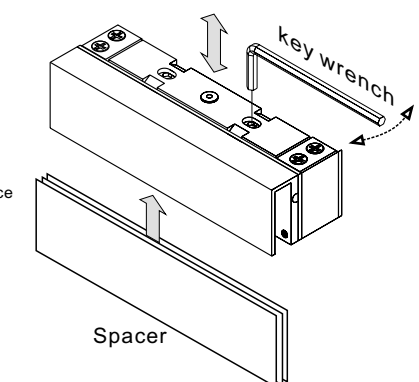

Spacer

**GS-300**  
(Surface Mount)

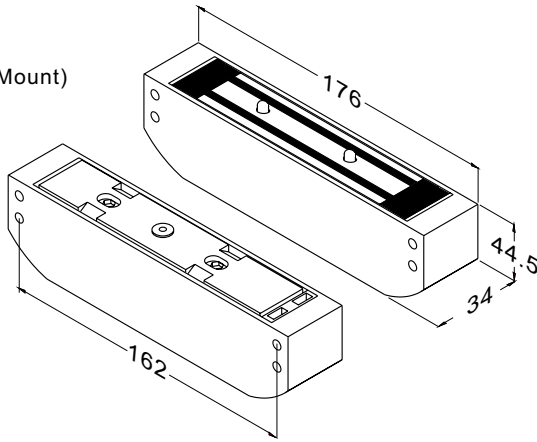

The **GS-300** mini surface mount shear lock with complete housing is specially designed for surface mounting door. The housing holds the magnet should be fitted above the door and the housing holds the Armature Plate should be installed on the door. It is essential to leave a minimum gap of 2mm between the Shear Lock and the Armature Plate, in order to perform the correct operation.

**Surface Installation**

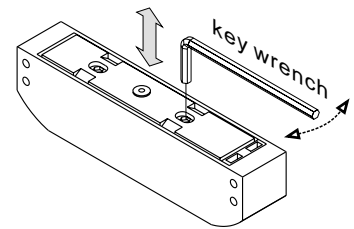
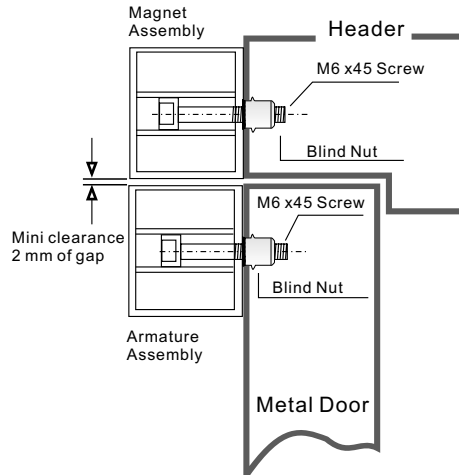
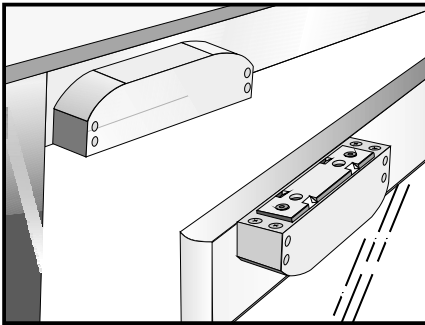

Using supplied key wrench to adjust armature plate to approx. 2 mm of gap between magnet surface.

**Blind Nut Installation**

Drill 9.4mm holes for M6 Blind Nuts.  
Drill 7mm holes for M5 Blind Nuts.

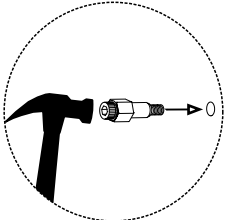

Insert two Blind Nuts into separate holes, one for each fixing screw.

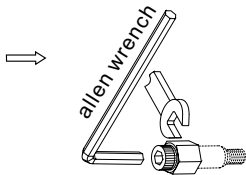

Use the allen wrench. To slowly tighten the Blind Nut. (Don't turning over)

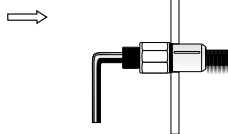

This compress the Blind Nut so that it remains permanently fixed in the frame.

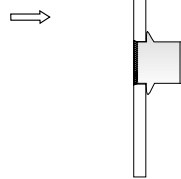

Remove the tool.

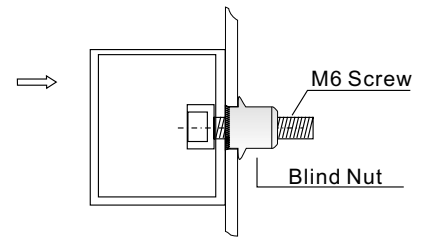

Use M6 Screws fixing SMB-001 brackets.

**Change the spring**

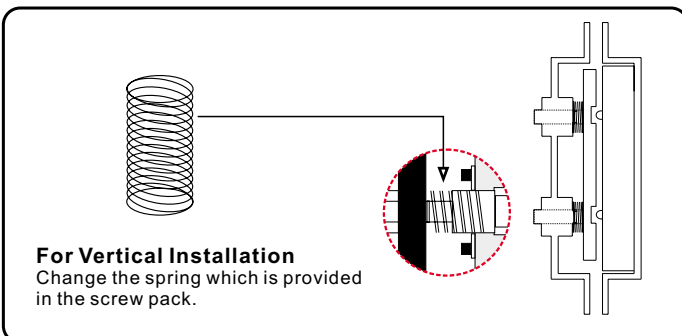

**For Vertical Installation**  
Change the spring which is provided in the screw pack.