

Villa application

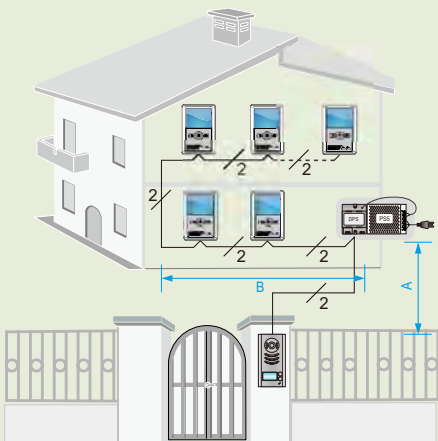

Cable and Distance

Cable	A(m)	B(m) ≤2 VT25	B(m) ≤16 VT25
CAT5 Cable (Combined)	40	80	—
Pair Cable (Parallel) 2X0.75 mm ²	30	50	—
Twisted Cable 2X0.75 mm ²	60	100	40
Twisted Cable 2X1.0 mm ²	80	120	60

Extending Monitors(up to 16)

In-Out topology:

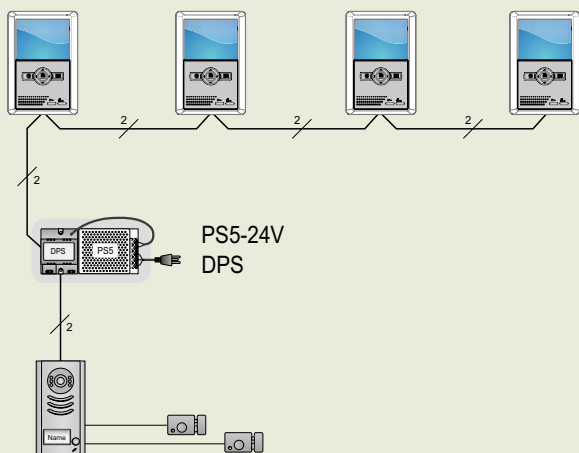

Star topology:

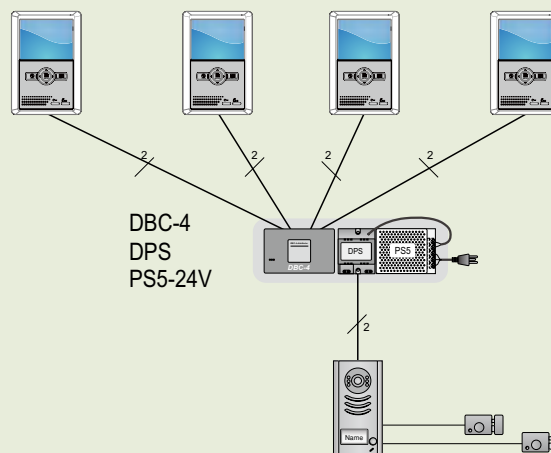

Extending Door/CCTV Cameras

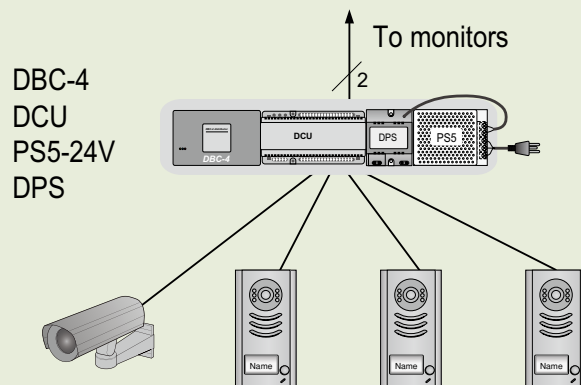
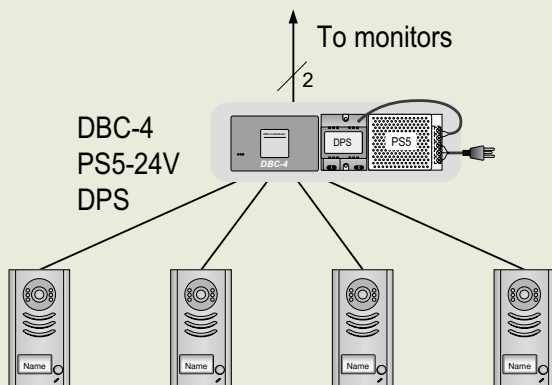

2 -Wire Intercom System

596SÚ User Manual



Programming the 596KP keypad Basic set up configuration

The manual for the 596KP is quite in-depth so please refer to the basic set-up as written below but also please read the manual carefully

Both door panel and video monitor have DIP switches to the rear of them which are used for different configurations, mainly they are used if you have multi door panel installations. If you have the basic system of 1 x door panel and 1 x video monitor then you do not need to worry about the DIP switches at all, they should all be set to the OFF position

To program the 596KP keypad for basic set up configuration in less than two minutes you will need to enter the program mode by entering the master default code

The default master code is 1234, so you would press 1234# (1 x hash)
The Red LED will light up to confirm you are now in the programming mode

If you do not press any button for up to 60 seconds the keypad will exit from the programming mode

To manually exit from the programming mode press the * key (1 x star)

To program a user code only – example code 9009

Enter the programming mode by pressing the master code of 1234# (1 x hash)
Press 21# – this is user code position 1
Press 9009# – this is your new user code, if successful the keypad will bleep twice
Press * to exit (1 x star)
Press the user code 9009# to test and the Red LED will light to confirm relay one is activated

To program the lock release timer

Enter the programming mode by pressing the master code of 1234# (1 x hash)
Press 03# then 09# for 9 seconds
Press * to exit (1 x star)
Enter 9009# and the keypad Red LED will light up for 9 seconds

To change the master default code of 1234 to 5678 (or your chosen number)

Enter the programming mode by pressing 1234# (1 x hash)
Press 01#
Press 5678# – this is your new master code, if successful the keypad will bleep
Press * to exit (1 x star)

Important:

do NOT forget your new mater code as you cannot reset the keypad without the master code

1. Parts and Functions

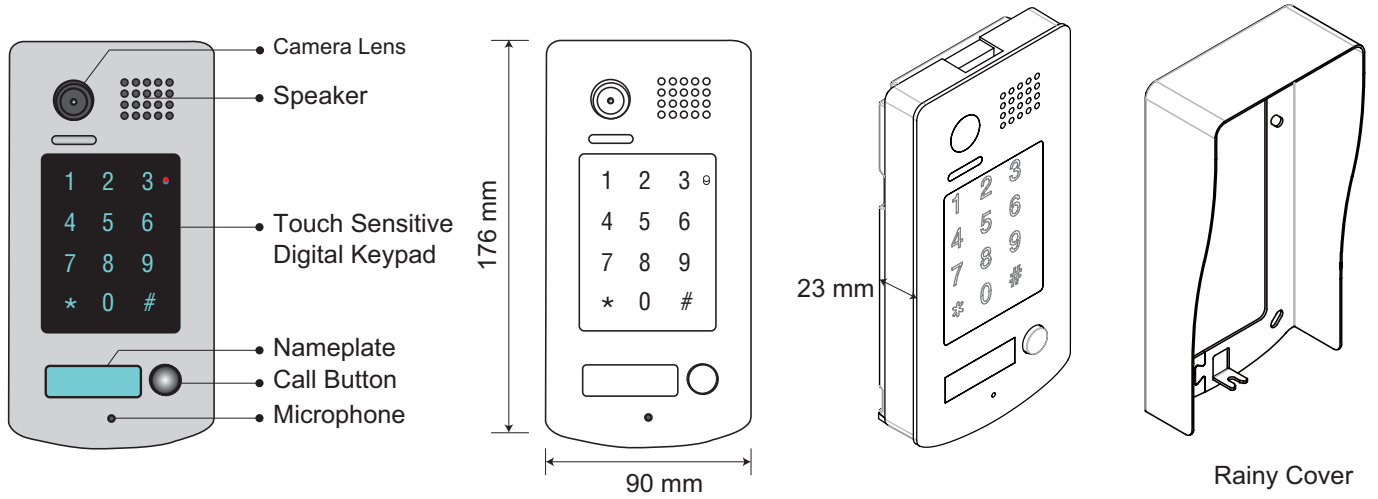

2. Terminal Descriptions

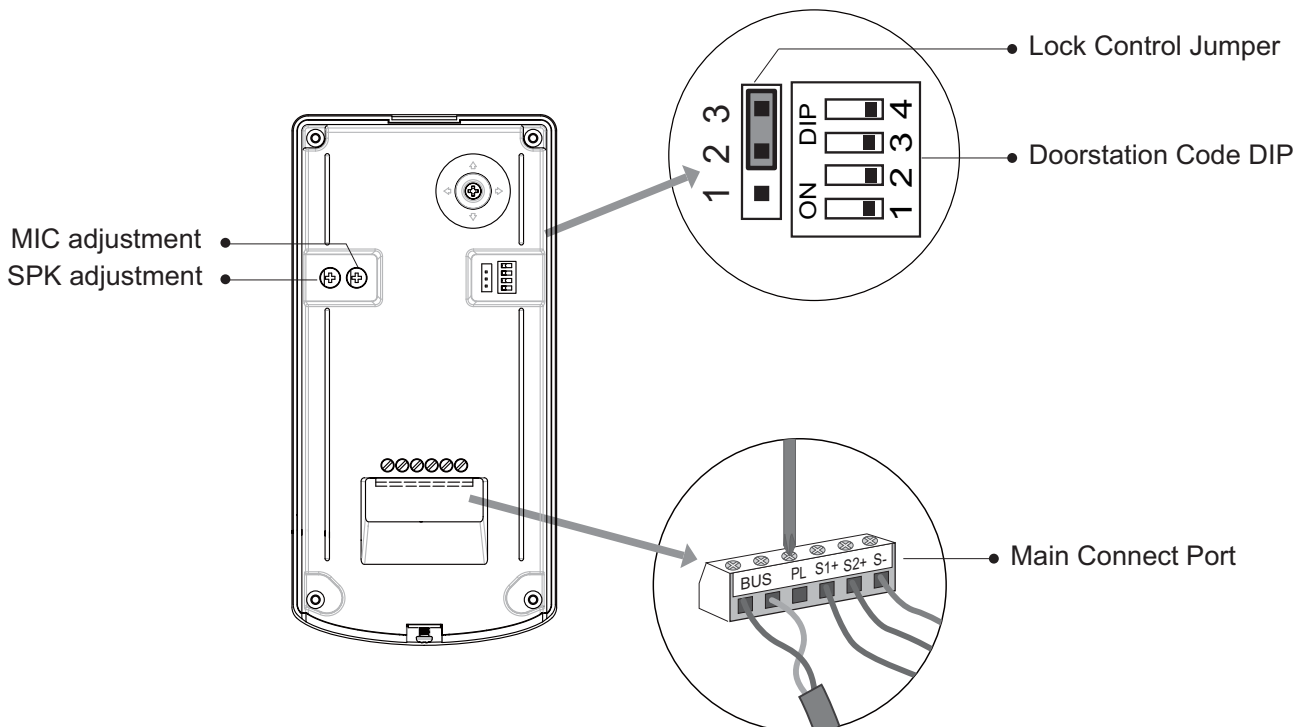

- **Lock Control Jumper:** To select the lock type: see section 5
- **Doorstation Code DIP:** Total 4 door stations can be supported, see section 6
- **MIC:** Adjust the volume of Microphone
- **SPK:** Adjust the volume of Speaker
- **Main Connect Port:** To connect the bus line and the electronic locks.
- **BUS:** Connect to the bus line, no polarity.
- **PL:** External lock power input, connect to the power positive(power +).
- **S1+, S2+:** Lock power(+) output, to connect 2 locks.
- **S-:** Lock power(-) output, connect to the power(-) input of locks(only when using the camera to power the locks, if using the external power supply for the locks, the S- will not be connected).

4. Door Station Mounting

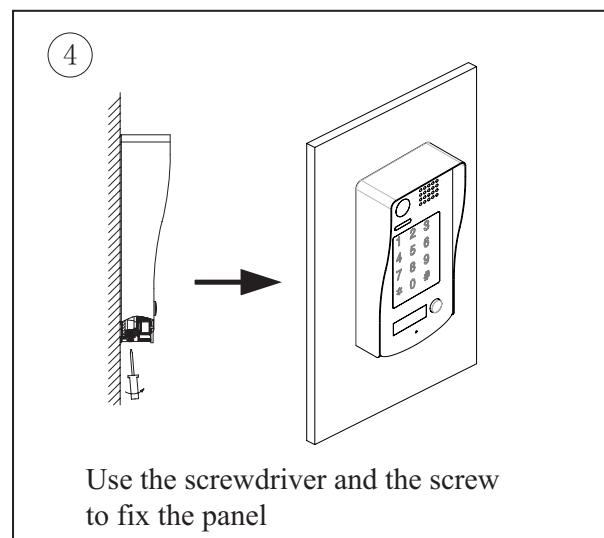
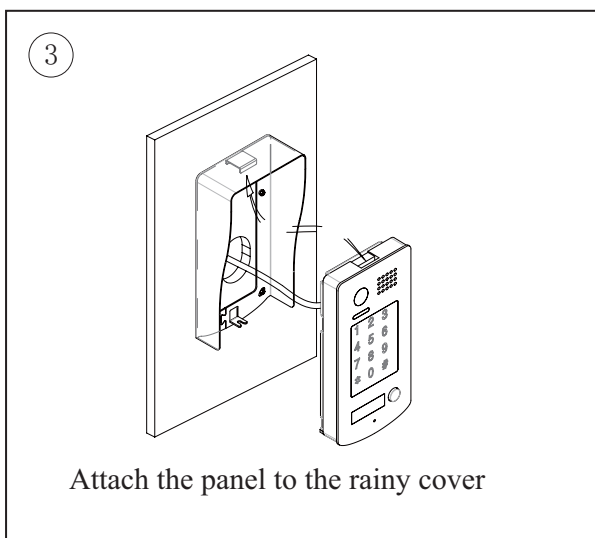
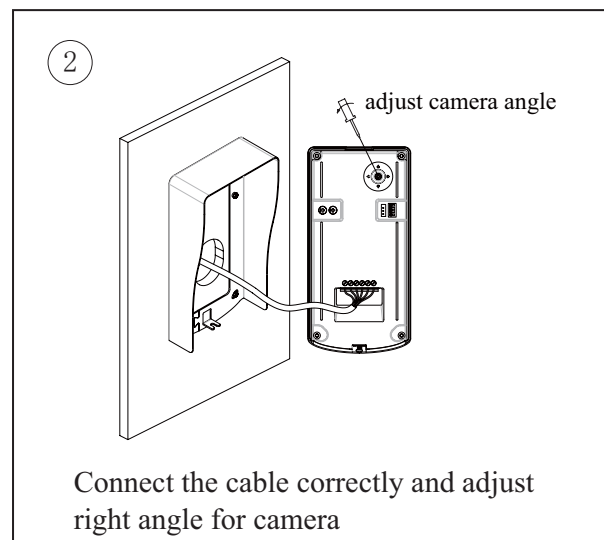
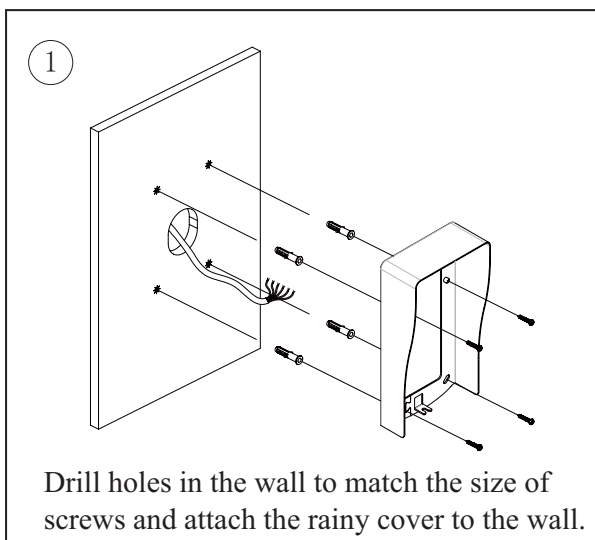

Placing Name Label

Move the plastic cover away to open the transparent name label cover, insert a name paper, then put the plastic cover back to the panel.

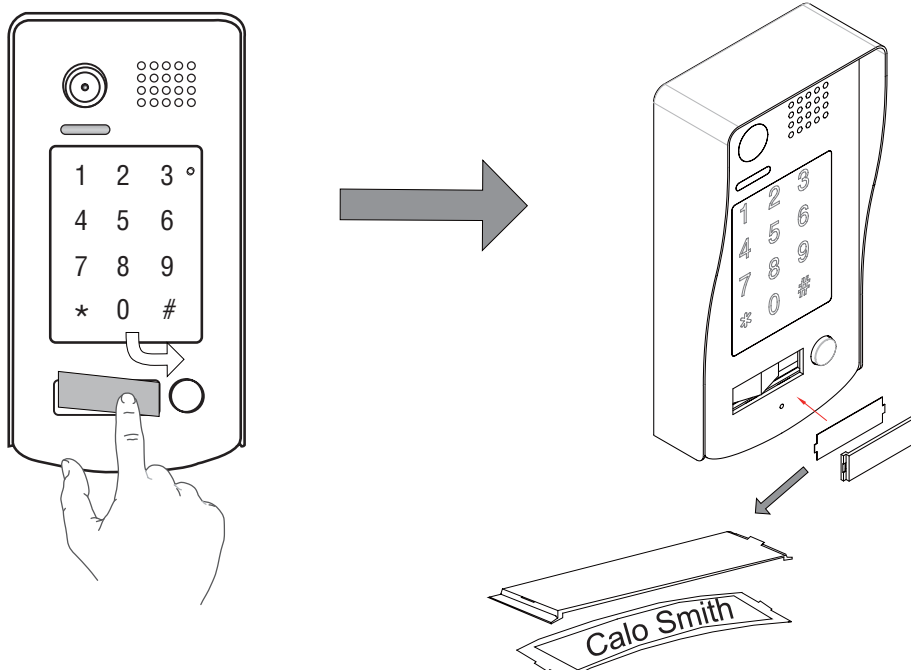

Adjusting Camera Angle

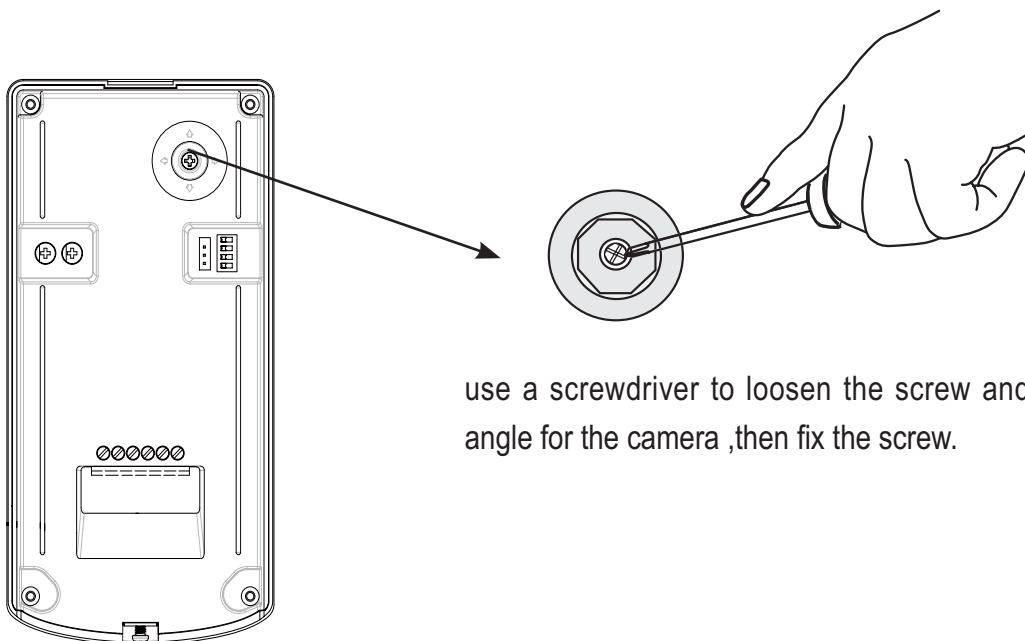

use a screwdriver to loosen the screw and adjust the angle for the camera ,then fix the screw.

5. System Wiring and Connections

Basic Connection

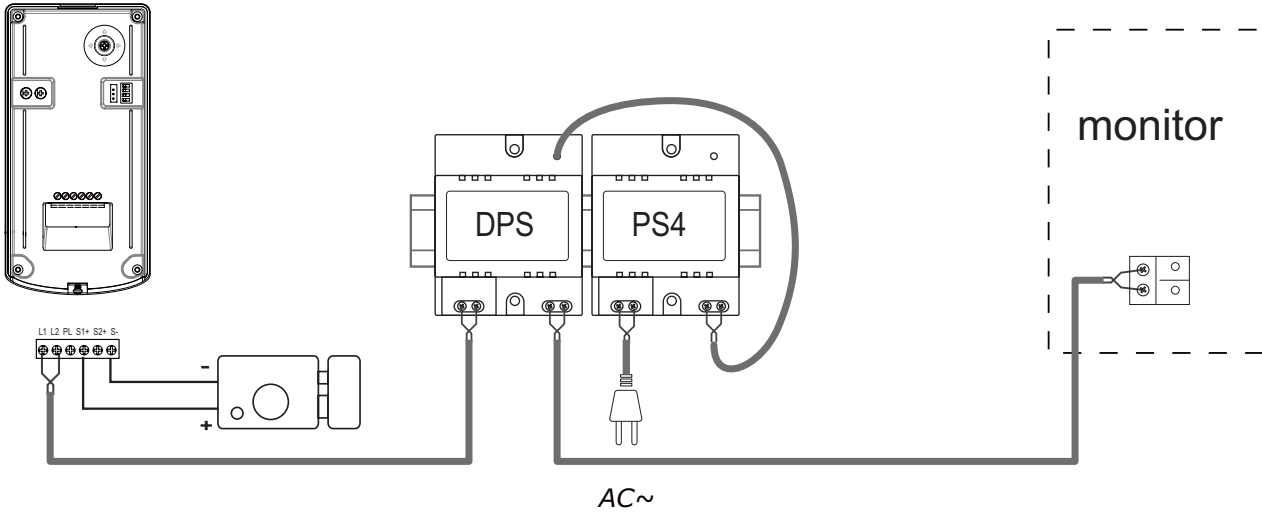

Electric Lock Connection

Door Lock Controlled with Internal Power

Note: Doentryonline Ltd recommend an additional power supply for any lock release used

1. Electronic lock of Power-on-to-unlock type should be used.
2. The door lock is limited to 12V, and holding current must be less than 250mA.
3. The door lock control is not timed from Exit Button(EB).
4. The **Unlock Mode** Parameter of Monitor must be set to 0 (by default).



Jumper position in 2-3

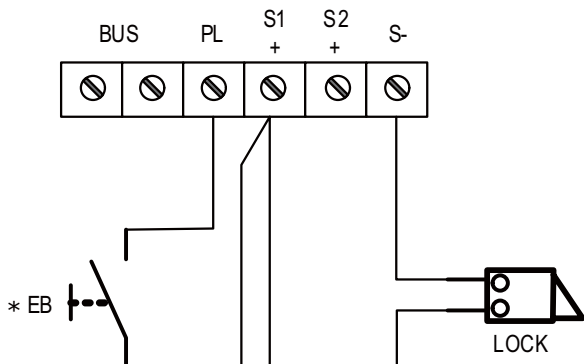

Jumper position in 2-3

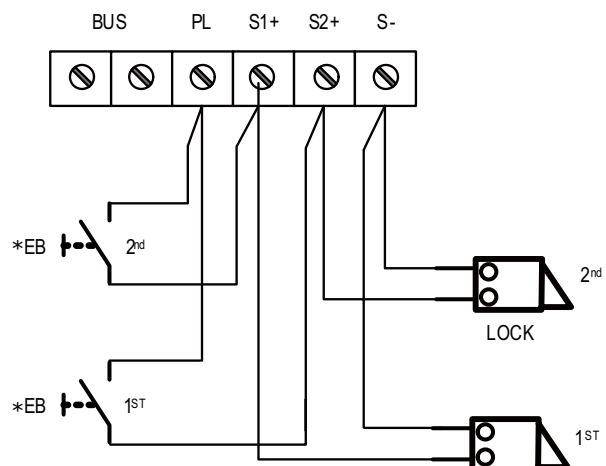

Connecting to a standard lock release

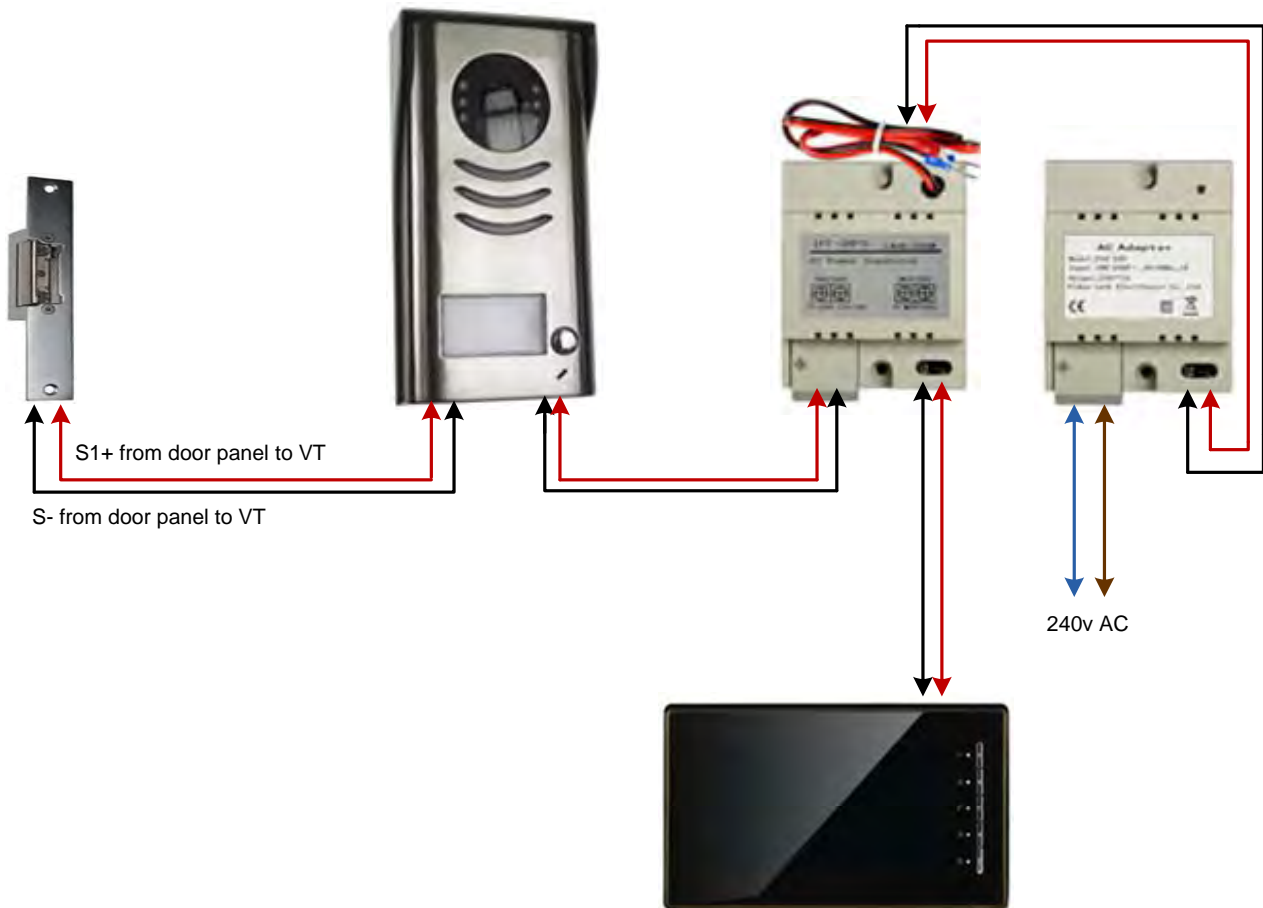



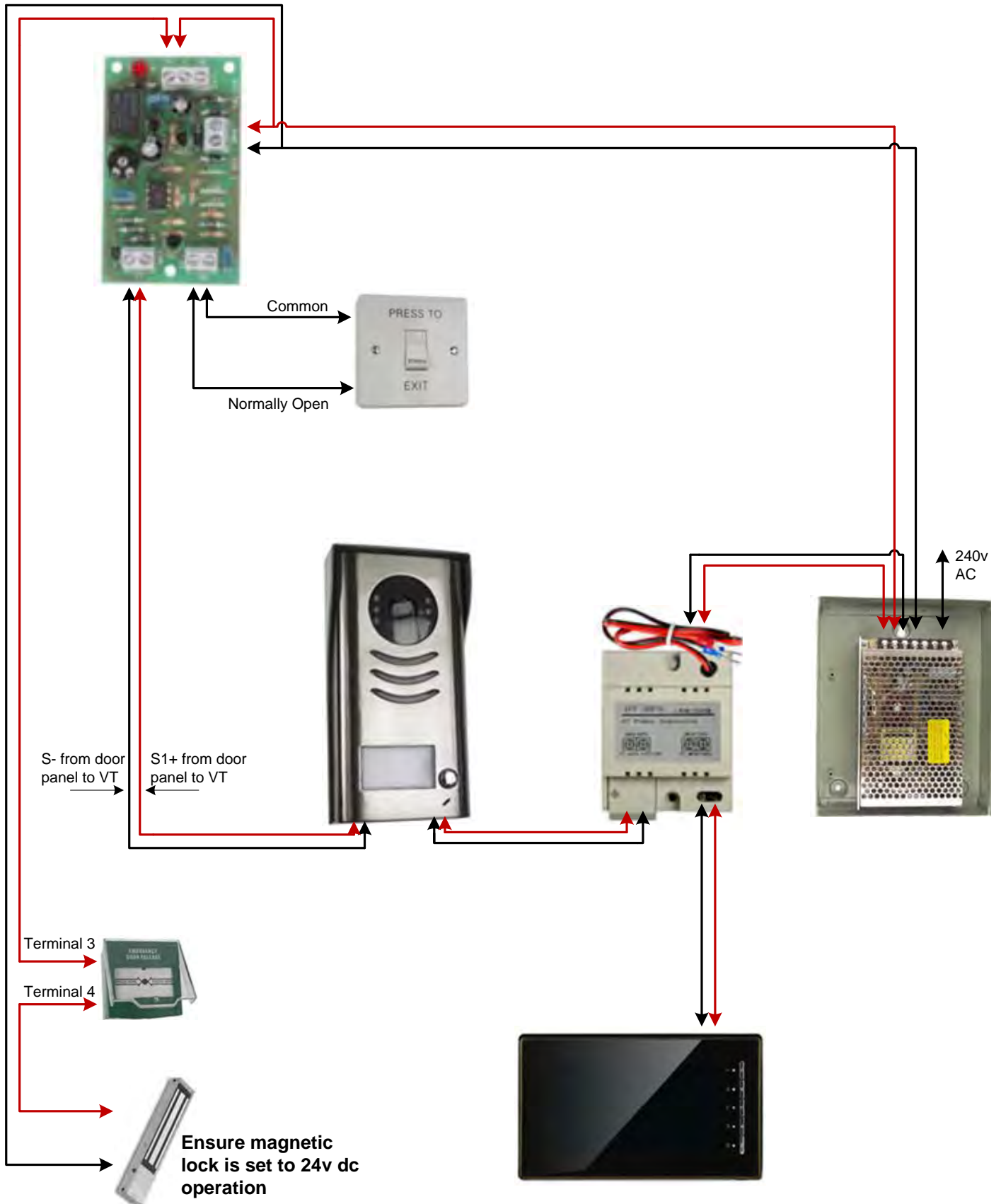



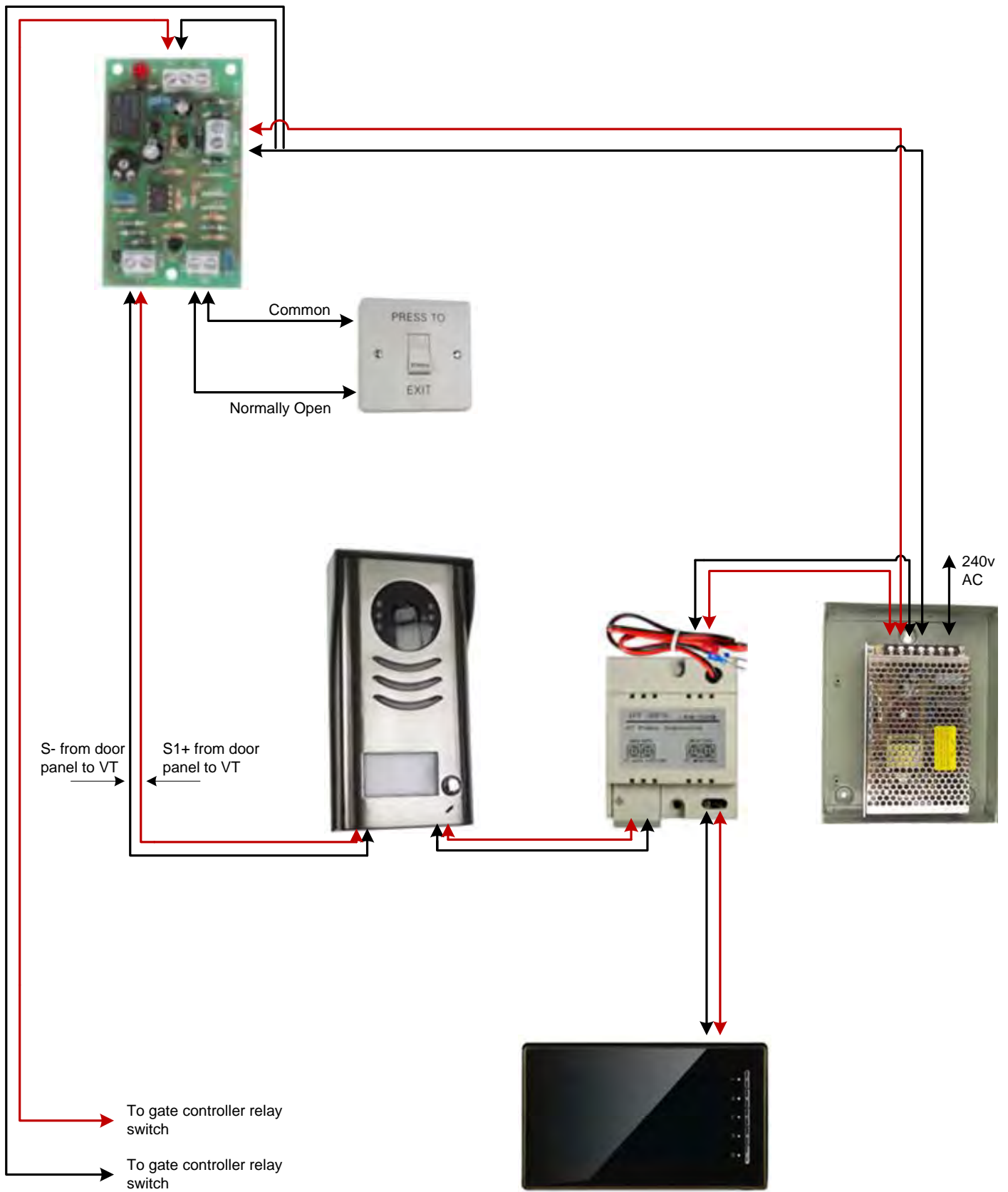





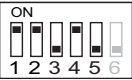

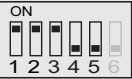
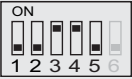
Connecting to a magnetic lock

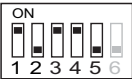

Connecting to an automated gate



Bit-1 to Bit-5 are used to User Code setting.The VT596 responds to 0~15 .

Bit state	User Code	Bit state	User Code	Bit state	User Code
	Code=0		Code=6		Code=11
	Code=1		Code=7		Code=12
	Code=2		Code=8		Code=13
	Code=3		Code=9		Code=14
	Code=4		Code=10		Code=15
	Code=5				

7. Functions Setting Up

This section explains the settings of each function, please refer to the following table:

About the setting mode:

Input the master code to switch to the setting mode, and input the corresponding setting code to perform the settings for the function you want. After settings have been made, input the following setting codes to continue the setting operation. Press "*" to exit the setting mode.



- The example is set * as cancel button and # as confirm button, please refer to */# function setting for detail information.
- Forbid to slide to touch the digital keypad, it may cause mistaken key, the correct operation is using your finger to press the digital you desired.
- You should press "confirm" button after finish inputting the code number each time, otherwise, the operation will be canceled automatically in 10s.

Order	Setting items	Setting range	Default value	Setting code
1	Reset all settings	1,2,3,4	-	00
2	Setting the master code	1 ~ 12 digits Valid keys:0 ~ 9	1,2,3,4	01
3	Setting the key illumination time	10 to 99 seconds/ continually lit	10 seconds	02
4	Setting the unlock time	01 to 99 seconds	1 seconds	03
5	Setting the unlock mode	0:opened/1:closed	opened	04
6	Operation tone settings	0:on/1:off	on	05
7	Reset code settings	1,2,3,4	-	06
8	*&# function settings	0:Normal/1:Reverse	Normal	07
9	Call tone settings	0:Enable/1:Disable	Enable	08
10	Interference resistant grade settings	Valid keys:0 ~ 5	2	09
11	Reserve(not used)	Reserve	Reserve	10~17
12	Setting the code forTemporary1	1 ~ 12 digits Valid keys:0~9	-	18
13	Setting the code forTemporary2	1 ~ 12 digits Valid keys:0~9	-	19
14	Setting the code for user group1	1 ~ 12 digits Number of codes:40 Valid keys:0~9	-	20~59
15	Setting the code for user group2	1 ~ 12 digits Number of codes:40 Valid keys:0~9	-	60~99

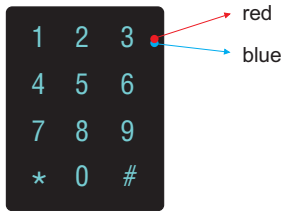

Each operation is indicated by the lighting up of the LED indicators on the right section of the unit, and by the sounding of the buzzer.

Input the master code.
(Default: [1 2 3 4] +[#])

(red) ON (blue) OFF
● ○ Beep+, Beep

1.Reset all settings 2.Setting the master code (Default : 1234) 3.Setting the key illumination time (Default : 10s) 4. Setting the unlock time (Default : 1s)

<p>Input the setting code. 00+#</p> <p>(red) ON (blue) ON ● ● Beep+, Beep</p>	<p>Input the setting code. 01+#</p> <p>(red) ON (blue) ON ● ● Beep+, Beep</p>	<p>Input the setting code. 02+#</p> <p>(red) ON (blue) ON ● ● Beep+, Beep</p>	<p>Input the setting code. 03+#</p> <p>(red) ON (blue) ON ● ● Beep+, Beep</p>
--	--	--	--

<p>Inputting of code 1234+#</p> <p>(red) ON (blue) OFF ● ○ Beep+</p>	<p>Inputting of new master code (ex.: 4321)(1~12 digits) 4321+#</p> <p>(red) ON (blue) OFF ● ○ Beep+</p>	<p>Inputting of code (ex.: 10) range:00 or 10~99 10+#</p> <p>(red) ON (blue) OFF ● ○ Beep+</p>	<p>Inputting of code (ex.: 09) range:01~99 09+#</p> <p>(red) ON (blue) OFF ● ○ Beep+</p>
---	---	---	---

- When the “ * cancel” key is pressed, the LED lights off, the buzzer beeps, and the system exits the setting mode

- When there isn't any operation in 10s, the LED lights off, the buzzer beeps, and the system exits the setting mode

(red) OFF (blue) OFF
○ ○ Beep, Beep+

- All settings will restore to their default value.
- When power on or activate the reset all setting item, the keypad checking will carry out, during this time, the key illumination will blink and the touching operation is forbidden, after finish checking, the key illumination will stop blinking and sent out a long sound of beep

- The master code is allowed 1~12 digits, the same code cannot be set for both the user code and the master code, it is recommended that you modify the default master code.

- If the key illumination time is set to 00, the key illumination will light up all the time when power on.
- If the key illumination time is set to 10~99, the key illumination will light up for 10~99 seconds. At this mode, the key illumination lights off in standby mode, touching any digital key can illuminate, but this is the invalid digital.

- The unlock time can be set on both monitor and door station, and the valid value is the number you set last time.

Input the master code.
(Default: [1 2 3 4] +[#])

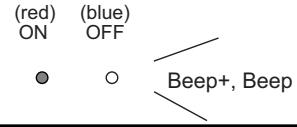

5. Setting the unlock mode (Default : 0(opened)) 6. Setting operation tone (Default : ON) 7. Reset code setting 8. *&# function setting (Default : Normal)

<p>Input the setting code. 04+#</p>	<p>Input the setting code. 05+#</p>	<p>Input the setting code. 06+#</p>	<p>Input the setting code. 07+#</p>
--	--	--	--

<p>0/1 Inputting of code (ex.: 1) range:0:(open)/1:(close) 1+#</p>	<p>0/1 Inputting of code (ex.: 1) range:0:(on)/1:(off) 1+#</p>	<p>Inputting of code 1234+#</p>	<p>0/1 Inputting of code (ex.: 1) range:0:(normal)/1:(reverse) 1+#</p>
---	---	--	---

- When the “ * cancel” key is pressed, the LED lights off, the buzzer beeps, and the system exits the setting mode

- When there isn't any operation in 10s, the LED lights off, the buzzer beeps, and the system exits the setting mode

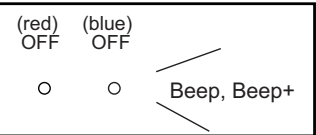

- The unlock mode can be set on both monitor and door station, and the valid value is the number you set last time.
- When the operation tone is set to 0, pressing the digital keypad will sent out a sound of beep.
- When the operation tone is set to 1, pressing the digital keypad will blink one time.
- Cancel all the passwords except the master code.
- Restore the master code to default value(1,2,3,4)
- When the item is set to 0, press the * button to cancel the input, and press the # button to confirm the input.
- When the item is set to 1, press the # button to cancel the input, and press the * button to confirm the input .

Input the master code.
(Default: [1 2 3 4] +[#])



9. Call tone setting (Default : enable) **10. Interference resistant grade setting (Default : 2)**

Input the setting code.
08+#

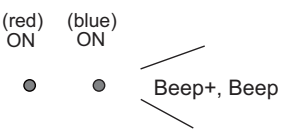

Input the setting code.
09+#

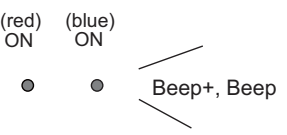

0/1
Inputting of code (ex.: 1)
range:0(enable)/1:(disable)
1+#

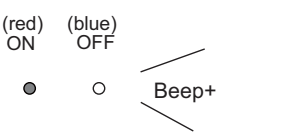

Inputting of code (ex.: 3)
range:0~5
3+#

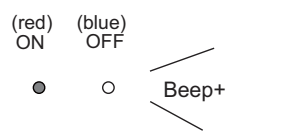

- When the “ * cancel” key is pressed, the LED lights off, the buzzer beeps, and the system exits the setting mode
- When there isn't any operation in 10s, the LED lights off, the buzzer beeps, and the system exits the setting mode

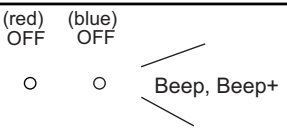

- If the item is set to 0, the unit will respond a call tone when pressing the “CALL” button.
- If the item is set to 1, the unit will have no responds when pressing the “CALL” button.

- The larger you set the interference resistant grade, the stronger it will be, but the sensitivity of the keypad will be more lower.
- The interference resistant grade setting also will activate the keypad checking.



12. Setting the code for Temporary1 13. Setting the code for Temporary2 14. Setting the code for user group1 15. Setting the code for user group2

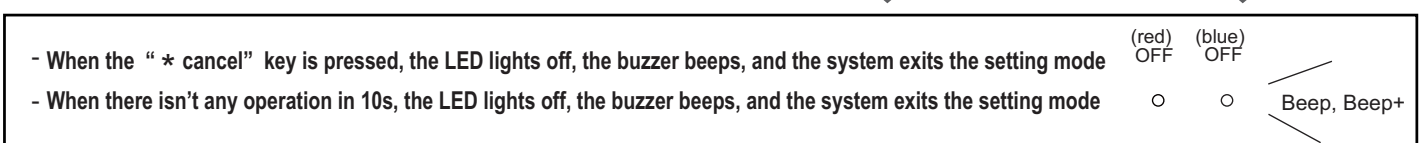
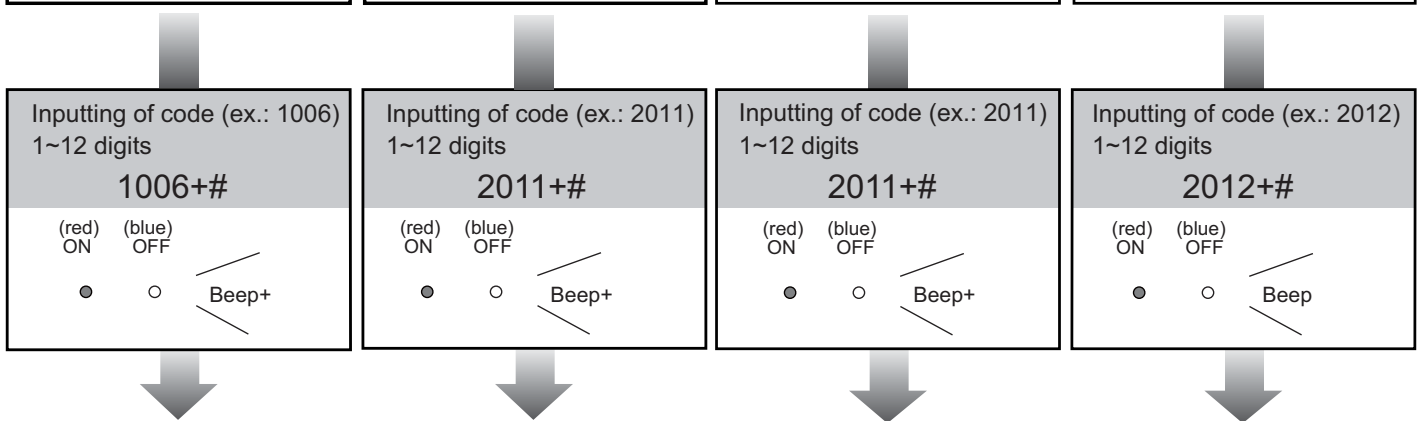
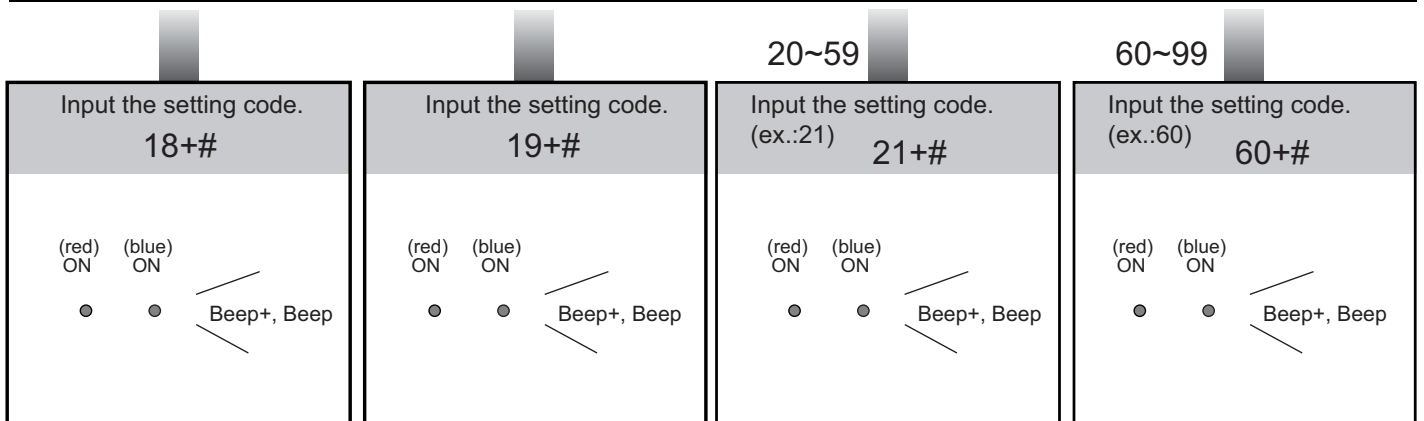

- When input the correct temporary password to release the door, the system will clear the temporary password after 60 seconds automatically. But you should know that the password is valid within 60 seconds after inputting the correct temporary password
- The temporary1 is used to release the first lock, and the temporary 2 is used to release the second lock.
- If the password length exceeds 12 digits, the system will send out the sound of “beep,beep,beep,beep”, and the digitals you input before will be cleared at the same time.
- The temporary code can not be set the same as the master code and user code.

- The user code group1 is used to release the first lock, and the user code group2 is used to release the second lock.
- The user code group1 and user code code group2 can contain 40 group passwords
- If the password length exceeds 12 digits, the system will send out the sound of “beep,beep,beep,beep”, and the digitals you input before will be cleared at the same time.
- The user code can not be set the same as the master code and temporary code.

8.Unlock Operations

Unlocking of user code

When the registered user code has been input using the keypad (1~12 digits), the LED indicator (group 1: red, group 2: blue) lights up, the buzzer sounds, and the electric door strike is unlocked.

Example:group 1
2011

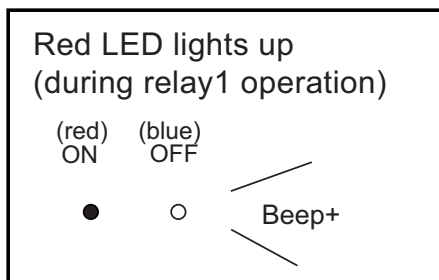

Example:group 2
2012

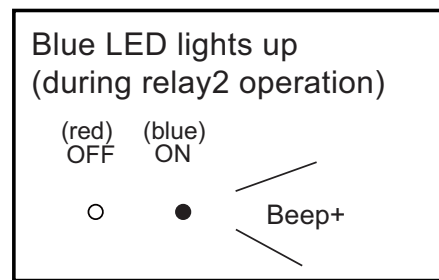

- The time interval during which the button must be pressed is approximately 10 seconds. If the time interval exceeds approximately 10 seconds, the input value will be cleared.
- If you make a mistake when inputting the user code, press the "cancel" button and input the user code again.
- When the "Lockout" function has been activated, the release function is forbidden and the input operation is disabled for 60 seconds if 10 times incorrect access codes are continuously attempted. ("Lockout" function: When "Lockout" is activated, the relay 2 doesn't respond the second lock but responds the LOCKOUT function. After continuously inputting incorrect access code 10 times, LOCKOUT output and the relay 2 will be closed for 60 seconds, the LED-relay 2 will be illuminated for 60 seconds) During this time, the buzzer will continuously sound about 8 times.
- You can activate the electric door strike by pressing the request to exit button connected to the unit. Pressing request to exit button 1 releases relay 1, and pressing request to exit button 2 releases relay 2. (The unlock function will work when the request to exit button is pushed, even while the "Lockout" function is operating.)



1. During calling, pressing "cancel" button can cancel the calling
2. If input the incorrect access code, the buzzer will sound of beep, beep, beep

9. Power Supply Instructions

Name	Description	Usage
PS5-24V	Power supply,85~260Vac input,24Vdc/3A output,10 DIN modules	Connect with multi doorstations or multi monitors(up to 2 or above)
PS4-24V	Power supply,85~260Vac input,24Vdc/1A output,for basic kit only,4 DIN modules	Connect with one doorstation and one monitor(DT16 can be connected two)

10. Precautions

- Please clean the unit with soft cotton cloth, don't use the organic impregnant or chemical clean agent. If necessary, please use a little pure water or dilute soap water to clean the dust.
- The unit is weather resistant. However do not spray high pressure water on access control keypad directly. Excessive moisture may cause problems with the unit.
- You must use the right adaptor which is supplied by the manufacture or approved by the manufacture..
- Pay attention to the high voltage inside the products, please refer service only to a trained and qualified professional.

11. Specifications

- Lock Power supply: 12Vdc, 300mA(Internal Power)
- Power Consumption: 2W in standby, 8W in working
- NO, COM dry contact: Max. 48V dc 1.5A
- Camera angle: Max. 72°
- Number of relay circuits: 2
- Mounting: Surface mounting
- Dimension: 176(H)X90(L)X23(D)mm
- Working temperature: -10°C ~ 45°C

12.Cables Requirements

The maximum distance of the wiring is limited in the VT system. Using different cables may also affect the maximum distance which the system can reach.

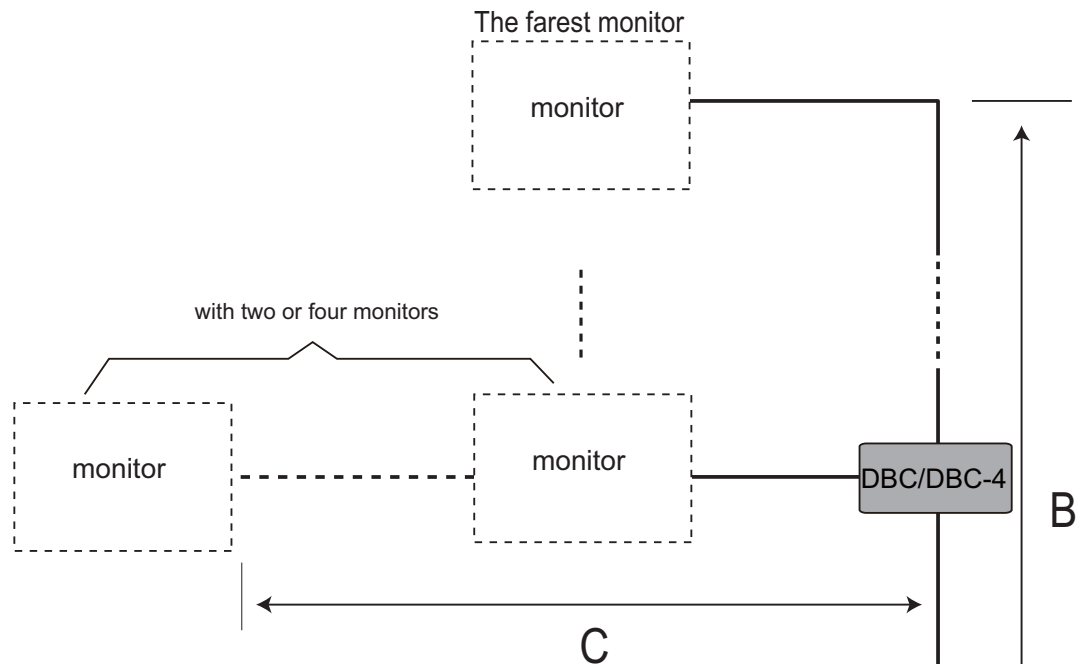

When Monitor quantity < 20

Cable Usage	A	B	C
Twisted cable 2x0.75 mm ²	60	60	30
Twisted cable 2x1 mm ²	80	80	40

When Monitor quantity > 20

Cable Usage	A	B	C
Twisted cable 2x1 mm ²	70	30	20
Twisted cable 2x1.5 mm ²	70	50	30

Note: If the monitor has been specified the distance, refer to the parameter.

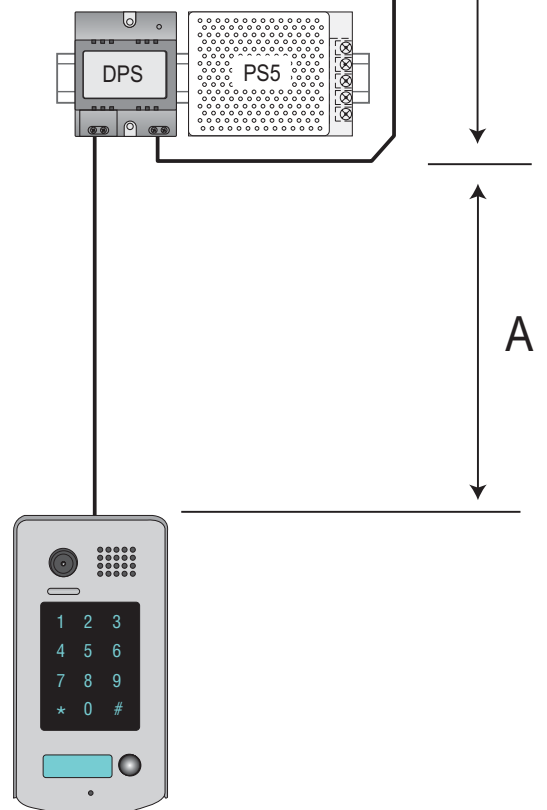

2 WIRE VIDEO MONITOR

USER MANUAL

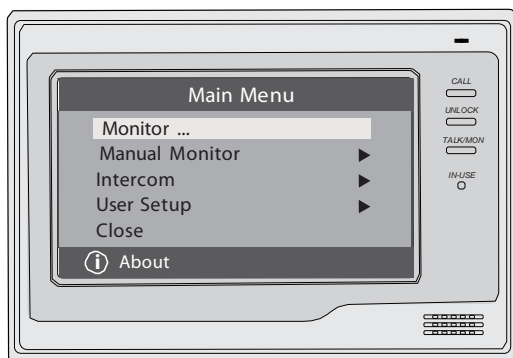

1. Parts and Functions

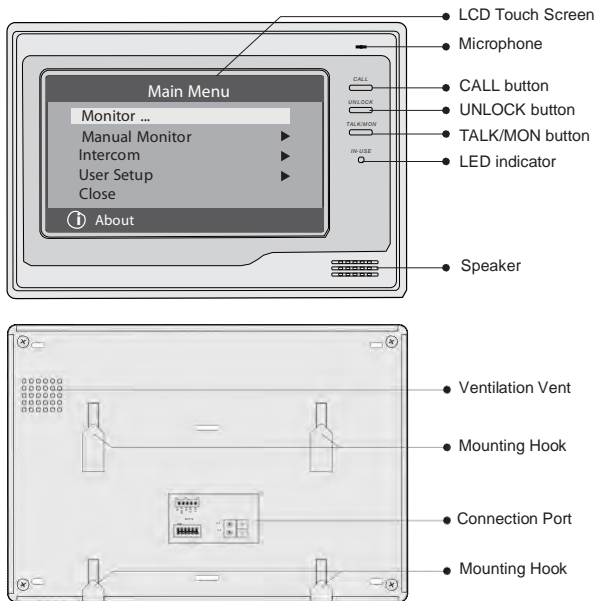

2. Monitor Mounting

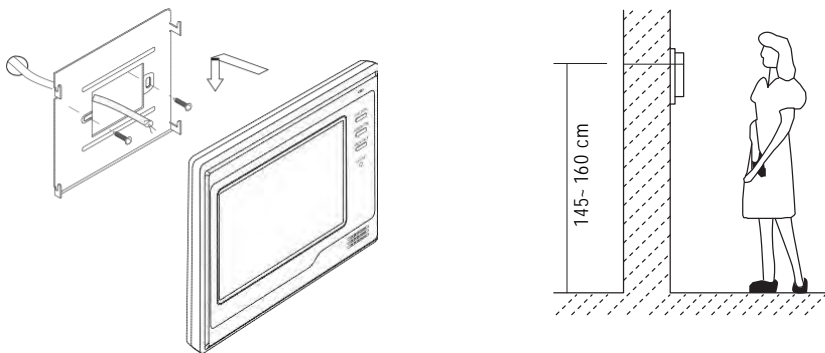



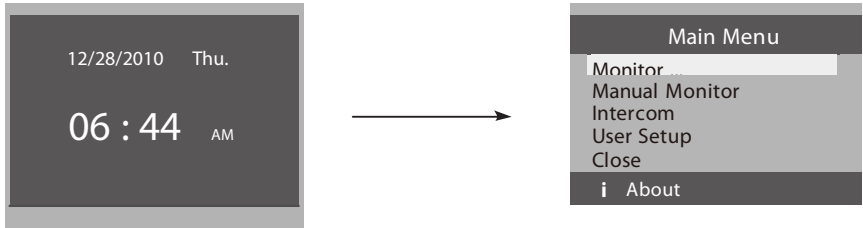

1. Use the screws to fix the Mounting Bracket on the mounting box.(fitting accessories includes a Bracket (Two pieces of 4X25 screws are needed for fastening the Mounting Bracket), Special 2 wire cables to connect with Monitor)
2. Wire the system correctly (see the later connection chapter) then hang the Monitor on the Mounting Bracket firmly.

3. Main Menu

1. Touch the screen anywhere on monitor in standby mode, the date/time page will be showed. (the date/time page will be closed in 1 minute if no operation)
2. Touch the screen again, main menu page will be showed as follows.



4. Basic Door Release Operation

1. Press **CALL** button on outdoor station, the Monitor rings, at the same time, the screen displays the visitor image.
2. Press **TALK/MON** Button on monitor or touch  icon on screen, you can communicate hands free with the visitor for 90 seconds. After finishing communication, press **TALK/MON** button again or touch  icon to end the communication. If nobody answers the phone, the screen will be turned off automatically after 30 seconds.
3. During talking state, Press **UNLOCK** Button or touch  or  icon to open the corresponding door for the visitor.
4. When the monitor is in standby mode, press **TALK/MON** Button(or touch **Monitor ...** item on main menu page), The screen can display the view of outside. If multi door stations are installed, touch  icon to get into the camera switch mode(or direct touch **Manual Monitor** item on main menu page). You can touch camera 1/2/3/4 to monitor the door station or CCTV camera you want. See the following diagrams.(Press **TALK/MON** button again to end monitoring.)

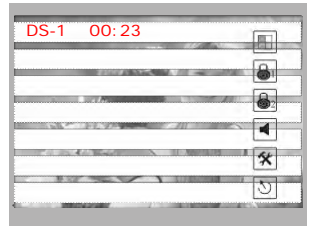

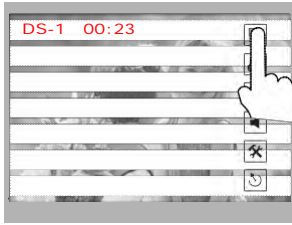

5. Intercom Function

When the monitor is in standby mode, press **CALL** Button to enter Intercom Function page(or direct touch **Intercom** item on main menu page).



1. **Intercom Call:** User in one apartment can call other apartments in the system. the name list will be created automatically by the system. Touch a name you want on the screen, then touch ☎ icon or press **CALL** Button on monitor to dial.(Note:1. touch ☎ icon or press CALL button again to redial. 2. Press TALK/MON button to cancel the call. 3.The DIP switches code of each monitor must set different.)



2. **Inner Call:** If multi Monitors are installed in the same apartment, select Inner Call, all the other Monitors will ring at the same time, whichever Monitor answers the call, conversation is started and the other monitors will stop ringing at the same time.(note: the DIP switches setting of all monitors must be same.)
3. **Direct Dial Guard unit:** A Monitor can be assigned as Guard Unit Monitor; when the Guard Unit Monitor answers the call, conversation with the guard person is started.

6. Basic Setup Instructions

Ring Tone Settings

Touch **User Setup** item on main menu page to enter setup page. Touch **Door Station Call Tone**, **Intercom Call Tone** or **DoorBell Tone** item, There are 12 ring tones that can be selected, touch a ring tone you want, then touch  icon to save and exit.(touch  icon to cancel the setting and return last page, touch  icon to get into main menu page)

Door Station Call Tone: set the ring tone calling from outdoor station.



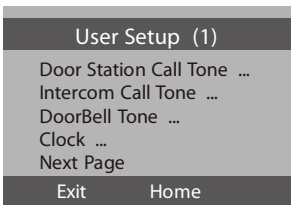

Intercom Tone: set the ring tone calling from other apartments.

DoorBell tone: set the ring tone calling from door bell.





Ring Volume and Night Ring Volume Setting

You can set a ring volume for day time and night time individually, 6:00 AM~18:00 PM is the day time and 18:00 PM~6:00 AM is the night time by default, if you don't want to be disturbed at night, you can set the night ring volume to 0.

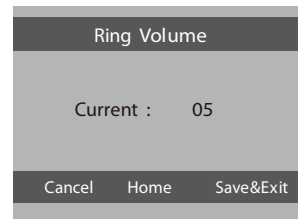
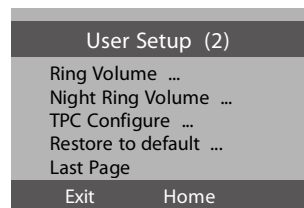
Touch **User Setup** item on main menu page to enter setup page, then touch **Next Page** item to enter User Setup 2 page, select **Ring Volume Setting** or **Night Ring Volume** item. then touch  /  icon to increase / decrease the value; After finish, touch  icon to save and exit.(touch  icon to cancel the setting and return last page, touch  icon to get into main menu page)







7. Date and Time Setting

Touch **User Setup** item on main menu page to enter setup page, touch **Clock...** item. a digital keypad will be showed on screen, input date and time by touching the digital keypad, use * icon to move the location. After finish, touch  icon to save and exit.(touch  icon to cancel the setting and return last page.)



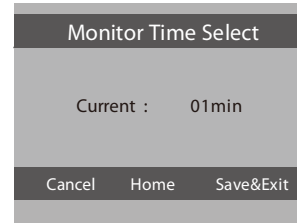

8. Monitor Time setting

Touch **Manual Monitor** item on main menu page to get into camera switch mode, select **Monitor Time Set...** item. touch  /  icon to increase / decrease the value; After finish, touch  icon to save and exit.(touch  icon to cancel the setting and return last page, touch  icon to get into main menu page)



9. Restore to Default

Touch **User Setup** item on main menu page to enter setup page, then touch Next Page item to enter User Setup 2 page, touch **Restore to default** item ,a message will be asked to confirm the restore operation. If touch  icon ,All settings will be restored to default, if you don't want to restore, touch  icon to cancel the operation.(Note that the restore to default operation will not change the time setting and the dates.)

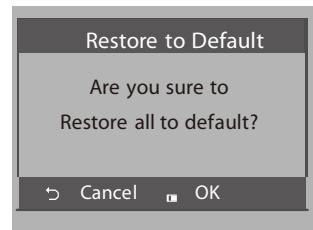
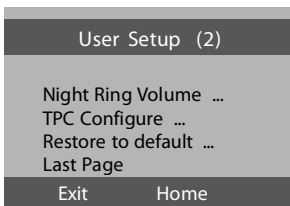

10. Unlock Parameter Setting

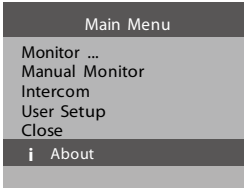

1.Touch User Setup item on main menu page.

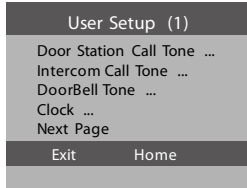

2.Touch Next Page item to enter next page menu.

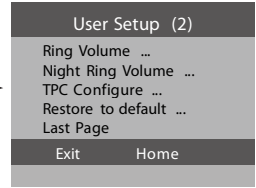

3.Touch Restore to default item, a message will be asked.

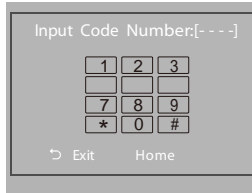

5.Input 4 digits code number by touching the digital keypad. ("*":cancel the input,"#":save the setting)



4.Press the UNLOCK button on monitor and hold for 2s.

Note:
8010 is used to set the unlock mode to 0. 8011 is used to set the unlock mode to 1.

11. Screen and Volume Adjustment

During monitoring or talking, touch  icon, the **ADJUST MENU** will be displayed. Select the adjustment item you want; touch  /  icon to decrease / increase the value.

- The first item is Scene mode selection: Total 4 screen modes can be selected in sequence: **Normal**, **User**, **Soft** and **Bright**. Whenever you modify **Brightness** or **colour**, **Scene** item will be set to **User** mode automatically.
- The **Brightness** and **Colour** item is for the image quality setting, adjust the value to get the best image you like.
- The **Ratio** item is for screen display adjustment, you can set to 16:9 or 4:3.
- The **Talk Volume** item is for talking volume adjustment.
- Note that all the modifications will be performed immediately after the operation. Touch  icon to exit the adjust page.

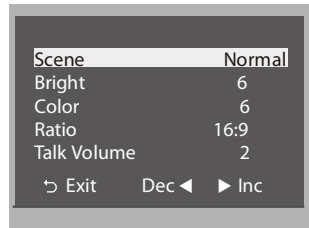

Additional Monitor Connections

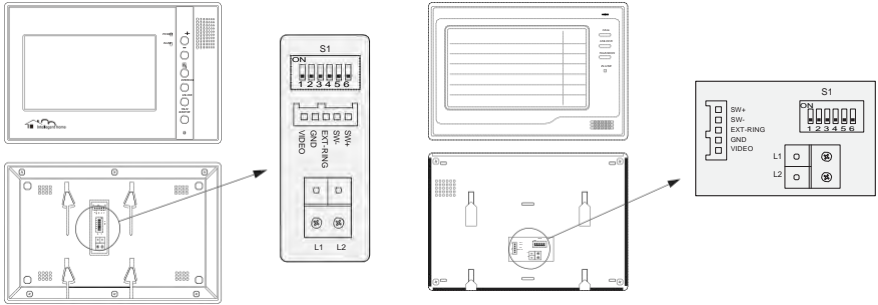

1. Door Bell Call Button

Additional door bell call button can be connected to the Monitor, so that the visitors can ring the door bell again in front of the user's apartment. When the call button is pressed, the Monitor will output ring tones but the screen will keep off, and the external ringer will ring at the same time (if a external ringer is installed).

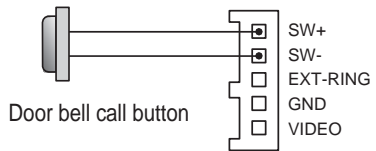

2. External Ringer

External ringer can be connected to the Monitor. The ringer will ring whenever the Door Station call button or the door bell call button is pressed, and it will stop ringing when the Monitor rejects or answers the call.

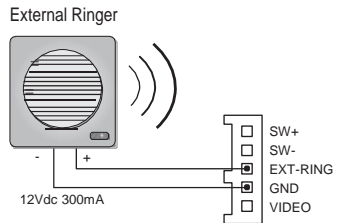

3. TV-out function

Connect television to the Monitor, when the Door Station calls, the user switch the channel to the AV channel, and the visitor's video will show up on the screen of the television. The core of the video cable must connect to the VD terminal, and the shielded layer connect to the GND.

