

EM-800SS External Magnet

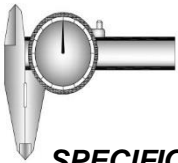

SPECIFICATIONS:

- ▶ **Voltage Input:** 12 VDC / 24 VDC
- ▶ **Current Draw:** 12V / 480mA ; 24V / 240mA (±5%)
- ▶ **Holding Force:** Up to 800 lbs (363 kg)
- ▶ **Hall Effect Contact:** 28 VDC, 0.2A
- ▶ **Anti-Rust Surface Treatment:** Zinc Plating
- ▶ **Operating Temperature:** -0~55°C (32~131°F)
- ▶ **Operating Humidity:** 0~95% (non condensing)
- ▶ **Weight (Magnet):** 1.3kg (±1%)
- ▶ **Dimensions:** Magnet - (L)220 x (W)46 x (D)28 mm
Armature - (L)180 x (W)44 x (D)12 mm



FEATURES:

- ▶ **All Parts Sealed for Water-Resistance**
- ▶ **Unique Dual Sides Installation Design**
- ▶ **Heavy Duty Stainless Steel Case for Vandal-Resistance & Anti-Corrosion**
- ▶ **Dual Voltage Selectable (12 VDC or 2VDC)**
- ▶ **Low Current Consumption**
- ▶ **Hall Effect Reed Monitoring Lock Status**
- ▶ **Reliable Holding Force**
- ▶ **Durable and Silence Operation**
- ▶ **Epoxy Sealed Surge & Spike Protection PCB**
- ▶ **Anti Residual Magnetism Kick Off Button**

IMPORTANT!

Before the power supply is switched on,
set the wiring correctly.

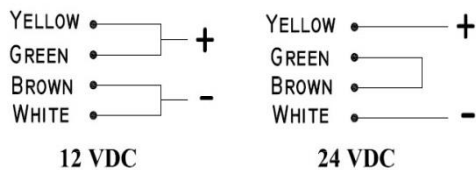

REED SENSOR CONTACT

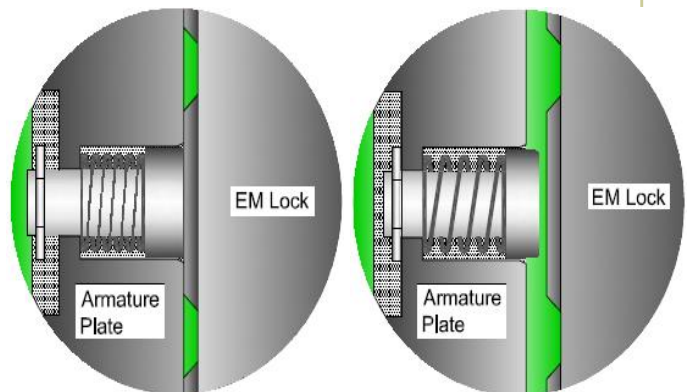
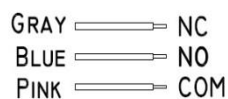

EM Lock Energized

EM Lock De-energized